



OWNER'S MANUAL

VALOR 48V

10048269-B

 **WARNING**

Read and comply with all of the instructions and safety precautions in this manual and on all product labels.

Failure to follow the safety precautions could result in serious injury or death.

California Proposition 65

 **WARNING**

Operating, servicing and maintaining a passenger vehicle or off-road vehicle can expose you to chemicals including phthalates and lead, which are known to the State of California to cause cancer and birth defects or other reproductive harm. To minimize exposure, wear gloves and wash your hands frequently when servicing your vehicle.

For more information go to www.P65Warnings.ca.gov/passenger-vehicle.

 **WARNING**

Never modify the vehicle in any way that will alter the weight distribution of the vehicle, decrease its stability or increase the speed beyond the factory specifications. Such modifications can cause serious personal injury or death. The manufacturer, E-Z-GO, prohibits and disclaims responsibility for any such modifications, or any other alteration which would adversely affect the safety of the vehicle.

OWNER'S MANUAL

RXV 48V LEAD ACID

VALOR
VALOR 4

MODEL YEAR 2023 - CURRENT

CONTACT INFORMATION

Textron Specialized Vehicles, Inc.

1451 Marvin Griffin Road

Augusta, Georgia, USA 30906-3852

1-800-774-3946 Technical Assistance & Warranty

1-888-438-3946 Service Parts

001-706-798-4311 International

www.ezgo.com

WELCOME

Thank you for purchasing this vehicle. Before driving your new vehicle, read this owner's manual to familiarize yourself with safe driving practices, operation, features, and controls.

This manual contains instructions for minor maintenance only. Information about major repairs can be found in the repair manual. Your dealer has thorough knowledge of your vehicle and wants your total satisfaction with your purchase. We recommend you return to your dealership for all of your service needs during and after the warranty period.

Repair or replacement parts can be purchased from your dealer or through the manufacturer's parts and accessories department.

These are original instructions as defined by 2006/42/EC.

Textron Specialized Vehicles, Inc. maintains the right to change the design of the vehicle without responsibility to make the changes on units purchased before changes were made. The information in this manual can change without notice.

All information in this owner's manual is based on the latest product information at the time of publication. Due to constant improvements in the design and quality of production components, some discrepancies may be found between your vehicle and the information presented in this publication. The content in this publication is intended for reference use only. The manufacturer is not liable for omissions or inaccuracies. Any reprinting or reuse of the content in this publication, whether whole or in part, is expressly prohibited.

Printed in USA

INTRODUCTION

MANUFACTURER'S INTENDED USE7
 WARRANTY AND REGISTRATION7
 BATTERY PROLONGED STORAGE8
 BATTERY DISPOSAL8
 VEHICLE IDENTIFICATION NUMBERS8
 SERVICE AND PARTS MANUALS8

SAFETY LABELS

SAFETY LABELS9
 Operation (P/N 664789)9
 Warning (P/N 608528)9
 Flip Seat / Load Deck Warning (P/N 697425) (Valor 4 Only)10
 Pinch Warning (P/N 651671) (Valor 4 Only)10

SAFETY

MAXIMUM CARGO LOAD / MAXIMUM WEIGHT CAPACITY11
 TIRE PRESSURE11
 OPERATOR SAFETY12
 Unauthorized Operation12
 Operating without Instruction13
 Alcohol or Drugs13
 Passenger13
 Before Operating13
 Load Operation13
 Driving in Reverse13
 Driving a Damaged Vehicle13
 Driving at Maximum Speeds13
 Driving on Public Roads14
 Turning14
 Driving Uphill14
 Driving Downhill14
 Stalling on a Hill14
 Tires14
 Slippery Terrain14
 VEHICLE LIFTING14
 VEHICLE MODIFICATION14
 MAINTENANCE SAFETY15

FEATURES AND CONTROLS

USB PORT (IF EQUIPPED)17
 CUP HOLDER17
 STEERING WHEEL17
 KEY SWITCH / DIRECTION SELECTOR18
 HEADLIGHT SWITCH (IF EQUIPPED)18
 TURN SIGNAL SWITCH (IF EQUIPPED)18
 STATE OF CHARGE METER (IF EQUIPPED)18
 ACCELERATOR PEDAL19
 BRAKE PEDAL19

TABLE OF CONTENTS

PARKING BRAKE	19
FORWARD FACING SEAT	19
HIP RESTRAINT	19
REAR FACING SEAT AND LOAD DECK (IF EQUIPPED)	20
REAR HAND RAIL	20
REAR GRAB HANDLE	20
OPERATION	
SAFETY	21
BEFORE INITIAL USE	21
INITIAL SERVICE CHART	21
DAILY INSPECTION	21
BATTERY CHARGER	22
PERFORMANCE FEATURES	22
Speed Control	22
Pedal-Up Braking	22
High Pedal Disable Feature	22
STARTING AND STOPPING THE VEHICLE	23
Starting on a Hill	23
ACCELERATING	23
BRAKING	23
Coasting	23
DRIVING PROCEDURE	23
DRIVING WITH PASSENGERS	24
SLIPPERY SURFACES	24
DRIVING UPHILL	24
TRAVERSING HILLSIDES	24
DRIVING DOWNHILL	25
STALLING ON A HILL	25
DRIVING IN REVERSE	25
PARKING THE VEHICLE	25
HAULING CARGO ON THE LOAD DECK (VALOR 4 ONLY)	26
Maximum Weight Capacity	26
Flip Seat/Load Deck Operation	26
MAINTENANCE	
MAINTENANCE SAFETY	27
SCHEDULED MAINTENANCE	27
SCHEDULED MAINTENANCE CHART	28
RECOMMENDED LUBRICANTS AND FLUIDS	29
REPLACEMENT OF MAINTENANCE ITEMS	29
VEHICLE CLEANING AND CARE	29
Washing the Vehicle	29
Polishing the Vehicle	29
BATTERY CONNECTIONS	30
LIFTING THE VEHICLE	30
Lifting the Entire Vehicle	31
Lifting the Rear of the Vehicle	31
Lifting the Front of the Vehicle	31
Lowering the Vehicle	31

TABLE OF CONTENTS

TIRES	32
Tire Pressure	32
Tire Repair	32
Tire Replacement	32
WHEELS	33
Wheel Removal	33
Wheel Installation	33
LIGHTS (IF EQUIPPED)	33
FUSE REPLACEMENT	33
TRANSPORTING VEHICLE	34
Hauling the Vehicle	34
Towing the Vehicle	34
REAR AXLE	34
Checking the Lubricant Level	34
BATTERY CHARGING AND MAINTENANCE	35
Safety	35
Battery Disposal	35
Battery	35
Battery Maintenance	36
At Each Charging Cycle	36
Monthly	36
Electrolyte Level and Water	36
Battery Cleaning	38
Prolonged Storage	38
Battery Charging	39
AC Voltage	39
Fault Diagnosis	39
Hydrometer	40
Using A Hydrometer	41
VEHICLE SPECIFICATIONS	
VALOR	43
VALOR 4	44

TABLE OF CONTENTS

INTRODUCTION

The following symbols appear throughout this manual and on vehicle labels. Your safety is involved when these symbols are used. Become familiar with their meanings before reading the manual.



DANGER indicates a hazardous situation that, if not avoided, will result in death or serious injury.



WARNING indicates a hazardous situation that, if not avoided, could result in death or serious injury.



CAUTION indicates a hazardous situation that, if not avoided, could result in minor or moderate injury.



The **PROHIBITION SAFETY SIGN** indicates an action **NOT** to take in order to avoid a hazard.



The **MANDATORY ACTION SIGN** indicates an action that **NEEDS** to be taken to avoid a hazard.



WARNING Failure to comply with the warnings in this manual can result in severe injury or death.



WARNING Read this entire manual carefully before operating this vehicle. Do not attempt to operate this vehicle until you have thorough knowledge of the controls and features.



WARNING Regular inspections and maintenance, along with good operating techniques, will help ensure your safe enjoyment of the capabilities and reliability of this vehicle.

This vehicle was designed and manufactured in the United States of America (USA). The standards and specifications in the following information originate in the USA unless otherwise indicated.

When servicing engines, all adjustments and replacement components must be per the original vehicle specifications to maintain the USA Federal and State emission certification applicable at the time of manufacture.

MANUFACTURER'S INTENDED USE

This vehicle is designed and manufactured for off road use only. Use on public streets, roads, or highways is illegal in most areas and increases the risk of an accident involving other vehicles and people. This vehicle does not meet FMVSS (Federal Motor Vehicle Safety Standards) for public street, road, or highway use.

Check all laws and regulations before choosing an area to operate your vehicle.

WARRANTY AND REGISTRATION

Register the vehicle at www.ezgo.com.

A vehicle warranty statement is included with the purchase of a new vehicle.

Use Original Equipment Manufacturer (OEM) approved parts to keep the vehicle warranty effective.

All information, including coverage, limitations, exclusions and how to obtain warranty service is included in the literature package with the purchase of the vehicle. It can also be obtained from an authorized dealer.

INTRODUCTION

BATTERY PROLONGED STORAGE

Batteries discharge over time. The rate of discharge changes according to the ambient temperature, the age of the battery, and the condition of the battery.

Completely charged batteries will not freeze in winter temperatures unless the temperature is less than -75°F (-60°C). For winter storage, the batteries must be clean, completely charged and disconnected from any electrical draw down.

The battery charger can remain connected to the vehicle to keep a full charge on the batteries while the charger is connected to an active electrical supply. If the power supply is disconnected or interrupted, the battery charger will continuously check the charge on the batteries. A continuous check of the batteries will pull power from the batteries.

The batteries must be checked and charged as required at least every 30 days.

BATTERY DISPOSAL

Lead-acid batteries are recyclable. Return discarded batteries to distributor, manufacturer, or lead smelter for recycling. For neutralized spills, put any residue in acid-resistant containers with absorbent material such as sand. Dispose of the container in accordance with local, state, and federal regulations for acid and lead compounds. Contact local or state environmental authorized people for the disposal information.

VEHICLE IDENTIFICATION NUMBERS

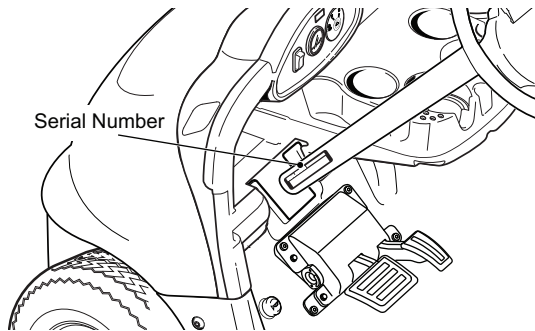

Serial Number Location on Steering Column

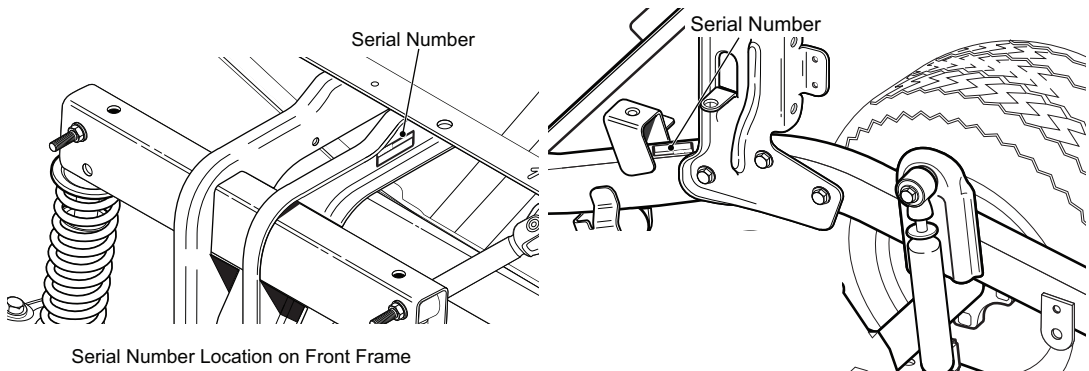

Serial Number Location on Front Frame

Record the vehicle identification numbers in the spaces provided below. These identification numbers are required when ordering parts from the manufacturer.

Serial Number: _____

SERVICE AND PARTS MANUALS

The following manuals can be purchased through an authorized dealer:

- service manual
- parts manual

SAFETY LABELS

SAFETY LABELS

Safety and warning labels are on the vehicle for your protection. Read carefully and comply with the instructions on the labels. If any label shown in this manual is different from the label on your vehicle, always follow the instructions on the vehicle label.

If a label comes off or becomes illegible, contact your dealer for a replacement. The part number is provided in this manual, printed on the label, or can be obtained from your dealer.

Operation (P/N 664789)

Located on the steering wheel.

WARNING READ AND OBEY THE FOLLOWING WARNINGS TO DECREASE RISK OF SEVERE INJURY OR DEATH. 664789

Pressing the accelerator pedal releases the parking brake even when the key is in the OFF position; the vehicle may move when the accelerator pedal is pressed. Unintentional movement of the vehicle can cause injury or death. Do not allow anyone to stand directly in front or behind the vehicle. • Driver must have a valid driver's license. • Do not operate vehicle until all occupants are properly seated with their backs against the seat and feet flat on the floor. • Do not leave children unattended or allow them to play on a parked vehicle.

SAFETY INSTRUCTIONS

BEFORE OPERATING

- READ the owner's manual and all warning labels. Contact an authorized dealer or go to the manufacturer's website for replacement manual or labels. • This vehicle is equipped for personal use in most communities; however, state law or local rules may require additional equipment in your community.

SAFE OPERATION & PARKING

- Turn key to ON, select Forward or Reverse, release the parking brake (if required), and slowly press accelerator pedal. • Always bring vehicle to a complete stop before shifting the direction selector. • Always remain seated in a moving vehicle. • Operate from the driver's seat only. • Never drink alcohol or use drugs or medications before or during operation of the vehicle. • ALWAYS engage the parking brake and remove the key before leaving the vehicle. In an electric vehicle, put the direction selector in OFF or Neutral; in a gasoline vehicle, put the selector in Forward.

MAINTENANCE & TOWING

- This vehicle requires regularly scheduled maintenance (see the periodic service schedule in owner's manual). • ONLY qualified personnel should service this vehicle. • Vehicle is not to be towed; consult owner's manual for transport instructions.

Warning (P/N 608528)

Located on the dash

WARNING Failure to follow these instructions can result in SERIOUS INJURY or DEATH. 608528

Except where PERMITTED BY LAW: NEVER drive on public roads. • Drivers must possess a valid drivers license in accordance with local state law.

AVOID FALLS from the vehicle: Do not start moving until all occupants are PROPERLY SEATED and HOLDING ON. • KEEP entire body INSIDE VEHICLE while moving.

Reduce the RISK OF ACCIDENTS: Always DRIVE SLOWLY in congested areas, on wet or loose terrain, and when backing up. • DRIVE SLOWLY when turning and AVOID sudden stops. ALWAYS drive straight up and down slopes. Do not coast, use BRAKE when going down a slope. • NEVER drive this vehicle under the influence of drugs or alcohol.

This vehicle is NOT A TOY: Drive responsibly. • NEVER leave children unattended or allow children to play on the vehicle. • NEVER leave the key in the vehicle when parked.

DO NOT OVERLOAD this vehicle: NEVER carry more than 2 occupants on each bench seat. • Do not exceed vehicle WEIGHT CAPACITY (see Owner's Manual).

DO NOT MODIFY this vehicle: NEVER alter this vehicle to increase travel speeds above factory specifications. • ONLY authorized E-Z-GO dealers should alter the vehicle using approved parts. • Alterations not approved or tested by E-Z-GO can create unsafe conditions and increase your chance of having an accident.

SAFETY

Flip Seat / Load Deck Warning (P/N 697425) (Valor 4 Only)

Located on the rear facing seat grab handle.

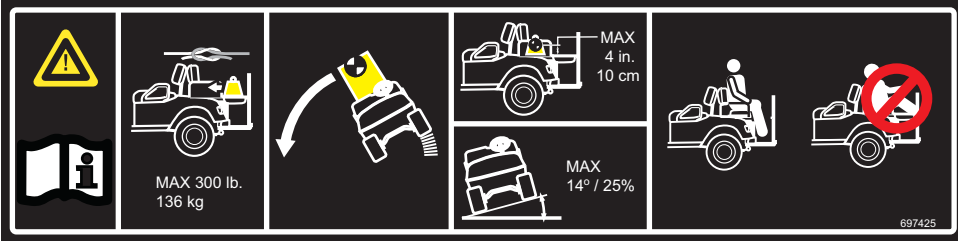

Pinch Warning (P/N 651671) (Valor 4 Only)

Located on the rear facing seat.



SAFETY

For questions about the vehicle or the material in this manual, see the contact information on page 1 or the back of this publication.

Certain replacement parts can be used independently and/or in combination with other accessories to modify a TSV manufactured vehicle to permit the vehicle to operate at or in excess of 20 mph. When a TSV-manufactured vehicle is modified in any way by the Distributor, Dealer or customer to operate at or in excess of 20 mph on public streets or roads, UNDER FEDERAL LAW the modified product will be a Low Speed Vehicle (LSV) subject to the strictures and requirements of Federal Motor Vehicle Safety Standard 571.500. In these instances, pursuant to Federal law the Distributor or Dealer MUST equip the product with headlights, rear lights, turn signals, seat belts, top, horn and all other modifications for LSVs mandated in FMVSS 571.500, and affix a Vehicle Identification Number to the product in accordance with the requirements of FMVSS 571.565. Pursuant to FMVSS 571.500, and in accordance with the State laws applicable in the places of sale and use of the product, the Distributor, Dealer or customer modifying the vehicle also will be the Final Vehicle Manufacturer for the LSV, and required to title or register the vehicle as mandated by State law.

Information on FMVSS 571.500 is found at Title 49 of the Code of Federal Regulations, section 571.500. For information on-line, go to www.ecfr.gov.

TSV will NOT approve Distributor, Dealer or customer changes that change a TSV product into a Low Speed Vehicle (LSV).

This vehicle meets the current applicable standard for safety and performance requirements.

MAXIMUM CARGO LOAD / MAXIMUM WEIGHT CAPACITY

⚠ WARNING Exceeding the maximum weight capacities can cause the loss of vehicle control and possible injury or death.

	Valor	Valor 4
Maximum Vehicle Weight Capacity	500 lb (227 kg)	800 lb (363 kg)
Maximum Load Deck Weight Capacity	N/A	300 lb (136 kg)

- Do not exceed the maximum vehicle weight capacity (includes weight of operator, passenger, cargo, and accessories).
- Always fill the forward facing seat to capacity prior to seating any passengers on the rear facing seat.

TIRE PRESSURE

⚠ WARNING Improper tire pressure or uneven tire pressure can cause the loss of vehicle control and possible injury or death.

Maintaining the correct tire inflation pressure is essential for safe vehicle operation. The inflation pressure can vary within the recommended range to suit the condition of the terrain.

TIRE PRESSURE RANGE	TERRAIN CONDITIONS	RECOMMENDATION
18 - 22 psi (124 - 152 kPa)	Hard surfaces or pavement	Inflate to higher pressure within the range; never exceed maximum pressure indicated.
	Soft terrain or turf	Inflate to lower pressure within the range to reduce potential damage to the terrain or turf.

SAFETY

OPERATOR SAFETY

Safe and responsible use of this vehicle is necessary to prevent dangerous conditions for the operator, passengers, and other people in the area of operation. See *OPERATION* on page 21 for information on the safe operation of the vehicle. Make sure to read, understand, and comply with all of this information to decrease the risk of personal injury or death.

⚠ WARNING Serious injury or death can occur if you do not follow the instructions and procedures shown in this owner's manual.

- Read this entire manual and all product labels carefully. Follow the safety information and operating procedures described.
- Operate your vehicle responsibly to prevent dangerous conditions for the operator, passengers, and other people in the area of operation
- Operate the vehicle responsibly and keep the vehicle in safe condition of operation.
- A damaged vehicle or a vehicle that is not functioning properly is dangerous and must not be operated until repairs are made.
- Do not carry a passenger until you have a minimum of two hours driving experience on this vehicle.
- Keep feet, legs, hands, and arms inside the vehicle at all times.
- The driver must keep both hands on the steering wheel and both feet on the floor or pedals.
- Inspect the vehicle before each use to make sure it is in safe operating condition. Perform the pre-ride inspection described in this manual. See page 21.
- Always have the vehicle checked by an authorized dealer if it is involved in an accident.
- Always put the direction selector in forward (F) and engage the parking brake before exiting the vehicle.
- Remove the key from the key switch when the vehicle is not in use to prevent accidental starting, unauthorized use by someone below the age of 16, or someone without a driver's license and proper training.
- Drive the vehicle at appropriate speeds for the terrain and conditions. Be aware of environmental conditions that change the terrain and your ability to control the vehicle.
- Do not drive on excessively steep hills. Evaluate the terrain before descending a hill. Drive slowly and deliberately. Use the brake to limit speed and maintain control. Sudden braking or turning can cause the loss of vehicle control. Drive straight down the hill. Do not drive across the hill.
- Operate only in approved areas. Follow all applicable safety rules for the area.
- Avoid driving on terrain that is too rough for the vehicle's capabilities and your driving skills.
- Before driving in the reverse direction, make sure the area behind the vehicle is clear. Accelerate slowly and avoid making sharp turns.
- Make sure the direction selector is in the correct position before pressing the accelerator pedal.
- Decrease speed before and during turns.
- Decrease speed when driving on wet or slippery surfaces.
- Bring the vehicle to a complete stop before moving the direction selector.
- Do not exceed the cargo or vehicle weight capacities. Do not exceed the occupant capacity. See *VEHICLE SPECIFICATIONS* on page 43 for the vehicle load and seat capacity.
- If there is a risk of lightning, leave the vehicle and look for a safe location to wait until the lightning has stopped.

Additional information about safety is included throughout this manual or can be obtained from your dealer.

⚠ WARNING Failure to operate this vehicle as instructed can cause collision, loss of control, or roll-over resulting in severe injury or death. Follow all safety warnings in this section of the owner's manual. See the *OPERATION* section of the owner's manual for operating procedures and additional safety information.

Unauthorized Operation



This vehicle is for adult use only. Any person below the age of 16 is not permitted to operate the vehicle.

Any person who does not have a valid driver's license is not permitted to operate the vehicle.

Any person who is below the height of 59 in. (150 cm) is not permitted to operate the vehicle.

Leaving the key in the key switch allows unauthorized operation of the vehicle by someone under 16 years of age, an unlicensed driver, or someone who does not meet the height requirement. Always remove the key from the key switch when the vehicle is not in operation.

Operating without Instruction

Operation of this vehicle without proper instruction increases the risk of an accident. The operator must understand how to operate the vehicle correctly in different situations and on different types of terrain.

All operators must read, understand, and comply with the owner's manual and all warning and instruction labels before operating the vehicle.

Alcohol or Drugs

Operation of the vehicle during or after consuming alcohol or drugs can adversely affect operator judgment, reaction time, balance, and perception.

Never drink alcohol or use drugs or medications before or during operation of the vehicle.

Passenger

All passengers must be at least 59 in. (150 cm) tall. Passengers must be able to sit with their back against the seat and both feet on the floor.

For additional safety and operational information, see *DRIVING WITH PASSENGERS* on page 24.

Before Operating

Perform the initial service before each use to make sure the vehicle is in safe operating condition. Failure to inspect and confirm that the vehicle is safe to operate increases the risk of an accident. See *INITIAL SERVICE CHART* on page 21.

Follow all inspection and maintenance procedures and schedules described in *SCHEDULED MAINTENANCE* on page 27.

Load Operation

The weight of cargo and occupants affects vehicle operation. Carefully calculate how the vehicle is loaded and how to safely operate it. Follow the instructions in this manual for loading guidelines and tire pressure.

Do not exceed weight capacities specified for the vehicle. Capacities are listed in *MAXIMUM CARGO LOAD / MAXIMUM WEIGHT CAPACITY* on page 11 of this manual and also on the label affixed to the load deck (if equipped). As passenger weight increases, cargo weight should be adjusted to ensure the maximum vehicle weight capacity is not exceeded.

Tire pressure must be adjusted to accommodate the load being carried. See *TIRE PRESSURE* on page 11 for pressure specifications.

Verify tire pressure, and drive slowly and carefully to maintain control of the vehicle if driving under any of the following conditions:

- passenger and/or cargo exceeds half the maximum weight capacity
- driving over obstacles
- towing
- climbing a hill

Driving in Reverse

Make sure the area behind the vehicle is clear before operating in reverse. After making sure it is clear and safe to operate in reverse, accelerate slowly. Avoid making sharp turns in reverse. Refer to *DRIVING IN REVERSE* on page 25 for operational information.

Driving a Damaged Vehicle

Driving a damaged vehicle is not safe. If the vehicle has been involved in any type of accident, have it inspected by a qualified service dealer to verify that it is safe for operation.

Driving at Maximum Speeds

Maximum speed operation increases the risk of loss of control. Always drive at a speed that is appropriate for the terrain, visibility, operating conditions, and your skill and experience level. Use the brake to control speed and maintain control of the vehicle.

SAFETY

Driving on Public Roads

Driving this vehicle on public streets, roads or highways could result in a collision with another vehicle. Never drive this vehicle on any public street, road, or highway. This includes dirt and gravel roads unless they are designated for off road use. Most areas prohibit the operation of this vehicle on public streets, roads, or highways and can result in traffic violations and fines.

Turning

Improper or careless turning can cause loss of traction, loss of control, accident, or rollover. Do not turn quickly or at sharp angles. Do not turn at high speeds. Practice turning at slow speeds before attempting to turn at faster speeds.

Driving Uphill

Do not climb hills that are too steep for the vehicle or your driving abilities. Loss of vehicle control or rollover can result from climbing hills incorrectly. Refer to *Driving Uphill* on page 24 for operational information.

Driving Downhill

Inspect the terrain before descending a hill. Avoid driving across hills. Use the brake to limit speed and maintain control. Loss of vehicle control or rollover can result from driving downhill incorrectly. Refer to *Driving Downhill* on page 25 for operational information.

Stalling on a Hill

A rollover can result from stalling or rolling backward while climbing a hill. Drive uphill at a constant speed. See procedure on page 25 for maintaining control of your vehicle if it stalls on a hill.

Tires

Operating the vehicle with the incorrect tires or with the incorrect or uneven tire pressure can cause loss of control or an accident. Always use the size and type of tires specified for the vehicle. See Vehicle Specification for proper tire type and size. Always maintain the correct tire pressures as specified in *TIRE PRESSURE* on page 11.

Slippery Terrain

Driving on rough, wet, or loose terrain increases the risk of loss of traction or control and accident or rollover. Drive slowly and use the correct turning procedures when operating on slippery surfaces.

Tires that have lost traction and then regain traction suddenly can cause loss of vehicle control or rollover.

Refer to *SLIPPERY SURFACES* on page 24 for operational information.

VEHICLE LIFTING

The vehicle must be on a firm and level surface for lifting. Remain constantly aware that the vehicle is not stable during the lifting process. Do not get under a vehicle until you verify that it is stable on the jack stands. Never get under a vehicle while it is on a jack only. Put wheel chocks in front of and behind the wheels that are not being lifted. Do not allow anyone to remain or get on the vehicle at any time during the lifting process.

Read and comply with all warnings and follow the lifting procedures described on page 30.

VEHICLE MODIFICATION

Do not install any accessory not approved by the manufacturer. Do not modify the vehicle to increase the speed or power. Any modifications or installation of accessories not approved by the manufacturer can create a safety hazard and increase the risk of injury.

The warranty will be terminated if the vehicle is modified to increase vehicle speed or power.

The warranty may be terminated if the original (or equivalent) replacement parts are not installed on the vehicle.

The addition of some accessories can change the handling characteristics of the vehicle. Use only manufacturer approved accessories and familiarize yourself with their function and effect on the vehicle.

MAINTENANCE SAFETY

Routine and scheduled maintenance of this vehicle is necessary to keep the vehicle in safe and reliable condition. This section of the manual provides safety information for performing maintenance on the vehicle. Make sure to read, understand, and comply with all of this information to decrease the risk of personal injury or death.



WARNING

Serious injury or death can occur if the instructions and procedures shown in this owner's manual are not followed.

- Read this entire manual and all product labels carefully. Follow the procedures and comply with the safety information in this manual and on the vehicle safety labels while performing vehicle service or maintenance.
- Use the tools shown in the tool list and wear the specified safety equipment when performing vehicle service or maintenance.
- Remove all jewelry before servicing the vehicle.
- Do not allow loose clothing or hair to contact the moving parts.
- Do not touch hot objects.
- The drive wheels must be lifted and supported on jack stands before performing any service to the powertrain while the motor is in operation.
- Use wheel chocks and support the vehicle on jack stands. NEVER get under a vehicle that is supported by a jack alone. Lift the vehicle following the instructions in *LIFTING THE VEHICLE* on page 30
 - When servicing the vehicle, always wear eye protection. Be careful when working around batteries, using solvents, or compressed air.
 - Use insulated tools within the battery area to prevent sparks or battery explosion.
 - To prevent the risk of battery explosion, keep all flammable materials, open flames or sparks away from the battery.
- Hydrogen gas is produced as a battery is charged. Charge the battery only in well-ventilated areas.
- Maintain constant awareness that some components are heavy, spring loaded, corrosive, explosive, can cause high amperage, or get extremely hot. Battery acid and hydrogen gas can cause bodily injury. Keep your hands, face, feet, and body away from any area that can expose them to injury in the event that an unexpected situation occurs.
- After making repairs or performing maintenance, test the vehicle in a safe area that is free from vehicle and person traffic.



FEATURES AND CONTROLS

Vehicle controls and indicators consists of:

1. Key Switch
2. State of Charge Meter
3. Head Light Switch (if equipped)
4. Turn Signal Switch (if equipped)
5. Malfunction Indicator Light (MIL)
6. Center Compartment
7. Power Outlet, 12V (if equipped)
8. USB Port (if equipped)
9. Accelerator Pedal
10. Brake Pedal
11. Horn Button (if equipped)
12. Charger Receptacle

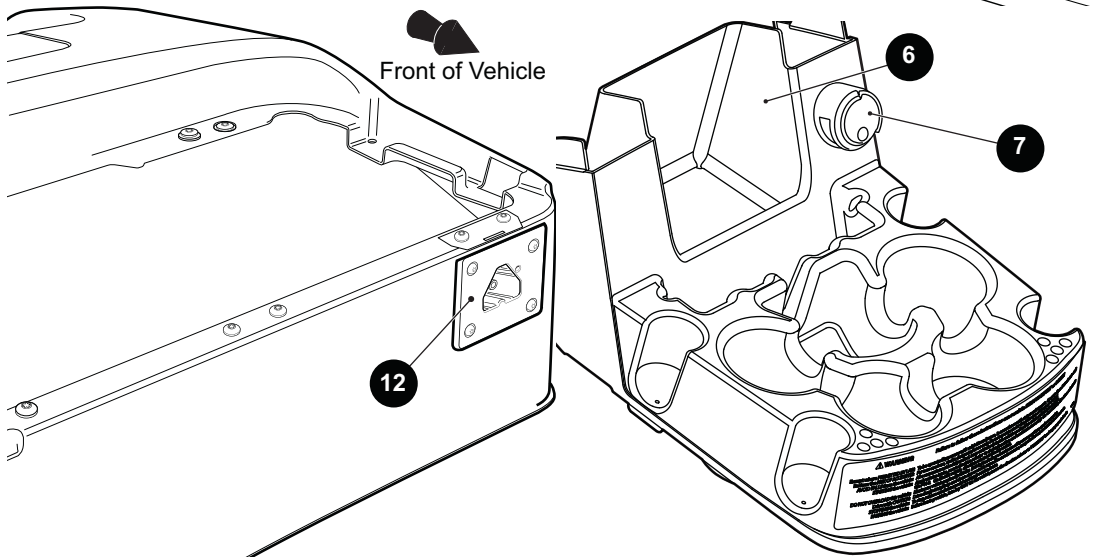
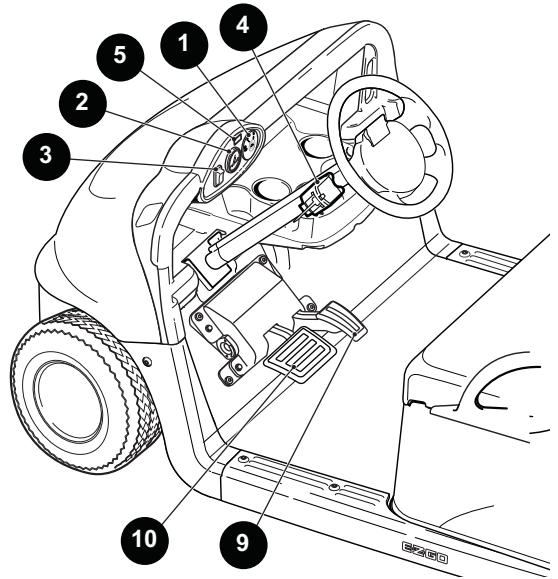

USB PORT (IF EQUIPPED)

A USB port (7) is located to the right of the center compartment.

CUP HOLDER

The vehicle has a cup holder for the benefit of both the driver and passenger.

STEERING WHEEL

The steering wheel controls the direction of vehicle travel.

FEATURES AND CONTROLS

KEY SWITCH / DIRECTION SELECTOR

⚠ CAUTION To decrease the risk of component damage, bring the vehicle to a complete stop before moving the key switch.

The key switch/direction selector is a four-position switch.

- OFF - vehicle is disabled.
- ON/N - activates vehicle electronics and accessory power.
- R - allows the vehicle to be driven in reverse and activates the reverse warning indicator.
- F - allows the vehicle to be driven in the forward direction.

NOTICE: Some factory installed accessories continue to operate with the key switch in the OFF position.

HEADLIGHT SWITCH (IF EQUIPPED)

The headlight ON/OFF switch (3) is located on the instrument panel to the left of the key switch (1).

TURN SIGNAL SWITCH (IF EQUIPPED)

The turn signal switch (4) is on the steering column and controls the operation of the right and left turn signal lights.

STATE OF CHARGE METER (IF EQUIPPED)

The state of charge meter (2) is on the dash panel beside the key switch. It indicates the amount of usable power in the batteries, with 100% indicating a full charge on the battery pack and 0% indicating no charge. The text "LOWBAT" indicates the batteries must be charged immediately. When the vehicle is in motion, the meter functions as a speedometer and hour meter.

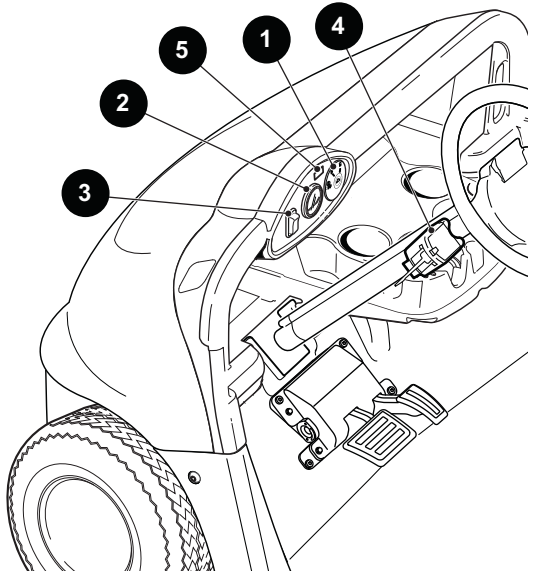

ACCELERATOR PEDAL



WARNING Accidental movement of the accelerator pedal can cause the vehicle to suddenly move and cause severe injury or death.

With the key switch in the ON position, press the accelerator pedal (12) to start the motor. When the pedal is released, the motor will stop. To stop the vehicle immediately, press the brake pedal (13).

When you press the accelerator pedal (12), the parking brake will be released if it is engaged. This is a feature to assure the vehicle is not driven with the parking brake engaged.

BRAKE PEDAL

The brake pedal is the wider pedal to the left.

Press the brake pedal to slow the speed or bring the vehicle to a complete stop.

PARKING BRAKE

This vehicle is equipped with an IntelliBrake, an automatic parking brake that is activated when the vehicle is stopped. The brake is released when the vehicle is in the F (forward) or R (reverse) position and the accelerator pedal is pressed.

FORWARD FACING SEAT

The seating capacity of the forward facing seat is two people, one person on each side of the seat.

HIP RESTRAINT

The hip restraints help people stay in position while the vehicle is in motion.

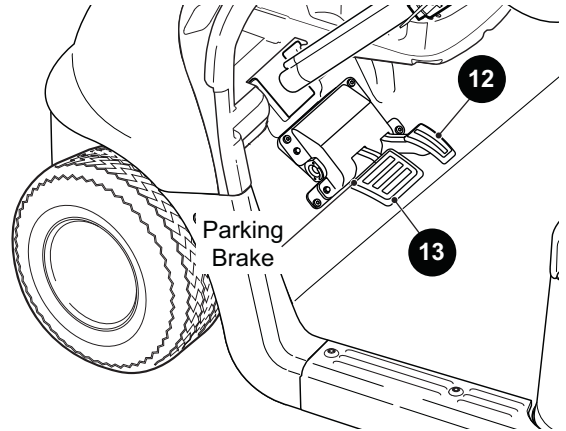

FEATURES AND CONTROLS

REAR FACING SEAT AND LOAD DECK (IF EQUIPPED)

⚠ WARNING

Passengers must stay in the seat and hold both the hand rail and rear grab handle while the vehicle is in motion.

Always fill the forward facing seat to capacity prior to seating any passengers on the rear facing seat.

Do not allow passengers to ride on the load deck. A sudden move or stop can cause severe injury or death to passengers on the load deck.

The rear facing seat capacity is two passengers, one person on each side.

Some vehicles have a feature that functions as a rear seat (18) or a load deck.

When in the upright position, it is a rear seat for two passengers. Fold the seat flat for a load deck.

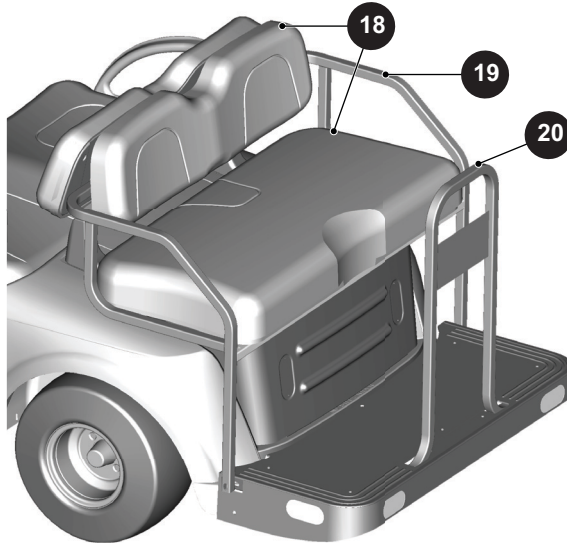

REAR HAND RAIL

There is a hand rail (19) on each side of the rear seat and a rear grab handle at the far rear of the vehicle to help passengers stay in position when the vehicle is in motion. The passengers must hold the rear hand rail whenever the vehicle is in motion.

REAR GRAB HANDLE

The rear grab handle (20) is located at the far rear end of the vehicle in the center of the rear footrest. The handle helps the passengers stay in position when the vehicle is in motion. The passengers must hold the rear hand rail and the rear grab handle whenever the vehicle is in motion.

OPERATION

SAFETY

WARNING

Failure to operate the vehicle correctly can result in a collision, loss of control, accident, or rollover, and cause serious injury or death. Follow all operation procedures in this section of the manual. Read and comply with all safety warnings in the safety section of this owner's manual.

BEFORE INITIAL USE

To prepare your new vehicle for operation, complete the following:

- Remove the protective plastic from the seats.
- Check for possible leaks that may have developed during shipment of the vehicle.

WARNING

Never charge a vehicle near flammable materials, open flame, or sparks. Never charge a vehicle near gas water heaters or furnaces.

- Charge the batteries fully. See *Battery Charging* on page 39
- Perform the following daily inspection.

INITIAL SERVICE CHART

INITIAL SERVICE CHART	
Item	Service Operation
Portable Charger	Remove from vehicle and correctly install.
Batteries	Charge batteries.
Seats	Remove protective plastic covering.
Brakes	Check operation.
	Calculate the distance necessary to stop the vehicle for the brake performance test.
Tires	Check air pressure (18 - 22 psi)
General	Check for possible leaks that may have started during shipment

DAILY INSPECTION

Inspect and verify that the vehicle is in safe operating condition before each use to decrease the risk of an accident. Check the items in the table to help ensure safe and reliable operation.

Item	Check
Brake system/pedal travel	Check for proper operation.
Front suspension	Inspect. Lubricate if necessary. Check for loose or missing hardware.
Rear suspension	Inspect. Lubricate if necessary. Check for loose or missing hardware.
Steering	Check for smooth and free operation.
Tires	Check condition and pressure. See page 32.
Wheel hardware	Check for loose or missing hardware.
Frame hardware	Check for loose or missing hardware.
Fluid leakage	Inspect vehicle for leaks.
Switches	Check operation.
Reverse warning alarm	Check operation.
Headlights (if equipped)	
Brake light / taillights (if equipped)	

OPERATION

BATTERY CHARGER

NOTICE: *The charger should be operated in accordance with the charger manufacturer's instructions. Always place the charger outside the vehicle before and during the charging cycle (does not apply to on-board charger). Never charge the battery pack in a hazardous environment.*

DANGER

Risk of electric shock. Connect the charger power cord to an outlet that is correctly installed and connected to an electrical ground according to all codes and regulations. A grounded outlet is necessary to decrease the risk of electric shock – do not use ground adapters or replace the plug. Do not touch parts of output connector or battery terminals that do not have insulation.

Disconnect the AC plug before you make or break the connections to a battery that is charging. Do not open or disassemble the charger. Do not operate the charger if the AC cord is damaged. Make sure qualified personnel does all repair work to the charger.

Refer to APPENDIX A for the charger manufacturer User's Guide for operating instructions, maintenance instructions and troubleshooting instructions.

The battery charger will test the temperature of the battery pack. If the temperature is too hot or too cold the charger will shutdown. If the batteries temperature is within the safe to charge range the charger will operate.

PERFORMANCE FEATURES

NOTICE: *The vehicle operates when the run/tow switch is in the RUN position.*

The speed of the motor is sensed and controlled by the controller.

Speed Control

WARNING

The speed control system is not an alternative for the brake. Use the brake to control speed and decrease the risk of injury.

Speed control system vehicles are equipped with a regenerative motor control system.

Example: If all of the following events occur:

- the vehicle is being driven down a slope
- the vehicle attempts to exceed the specified top speed with the accelerator pedal pressed

the regenerative brake will limit the speed of the vehicle to the specified top speed. When the regenerative braking system is activated by this sequence of occurrences, the motor generates power which is returned to the battery pack.

Pedal-Up Braking

Pedal-up braking is regenerative braking that occurs when the accelerator pedal is released while the vehicle is moving.

Example: If both of the following events occur:

- The vehicle is being driven down a slope
- The accelerator pedal is released

The pedal-up braking will slow the vehicle until the vehicle stops or the accelerator is applied. When the pedal-up braking system is activated by this sequence of events, the motor generates power that is returned to the battery pack.

High Pedal Disable Feature

High pedal disable prevents acceleration if the key switch is turned on while the accelerator or brake are pressed. To reset the controller after a High Pedal Disable place both feet on the floor, then press the accelerator.

STARTING AND STOPPING THE VEHICLE

All vehicles have an *interlock system* that disables the controller and prevents operation or towing of the vehicle while the charger is connected. Remove the charger plug from the receptacle and correctly store the cable before moving the vehicle.

1. Sit in the driver's seat.
2. Insert the key and turn the key switch to the desired direction (F or R).

NOTICE: *When the direction selector is moved to the reverse position, a warning alarm will activate to indicate that the vehicle is ready to run in reverse.*

3. Slowly press the accelerator pedal to start the motor.
4. When the accelerator pedal is released, the motor decreases the speed of the vehicle. To stop the vehicle more quickly, press the brake pedal.
5. Turn the key switch to the OFF position and remove the key from the switch before exiting the vehicle.

Starting on a Hill

The IntelliBrake™ (parking brake) will activate automatically when the vehicle stops. To start the vehicle on a hill, press the accelerator pedal and the parking brake will release.

ACCELERATING



WARNING

Accidental movement of the accelerator pedal can cause the vehicle to suddenly move and cause severe injury or death.

Apply slow and steady pressure to the accelerator pedal to start the motor and accelerate the vehicle. When the accelerator pedal is released, the motor decreases the speed of the vehicle.

BRAKING



WARNING

When carrying cargo or towing a vehicle or trailer, the weight of the load will increase the braking distance required to slow or stop the vehicle. Not allowing for increased braking distance under load can cause an accident or injury.

1. Release the accelerator pedal completely.
2. Press the brake pedal to slow vehicle speed or stop the vehicle completely.
3. Practice slowing and stopping using the brake to become familiar with the controls.

Coasting

The vehicle has a braking feature (pedal-up) that decreases the speed when the accelerator pedal is released. The feature continues to decrease the speed until the vehicle stops. Press the brake if you need to decrease speed or stop the vehicle quickly.

DRIVING PROCEDURE

1. Perform the daily inspection on page 21.
2. Sit in the driver's seat.
3. Check the surroundings and determine the path of travel.
4. Insert the key into the key switch and turn the key switch to the desired position (F or R).
5. Slowly press the accelerator pedal to start the motor and accelerate.
6. Practice maneuvering the vehicle using the accelerator and brake pedals. Drive slowly and cautiously until you are comfortable with the controls.

OPERATION

DRIVING WITH PASSENGERS

- Do not allow more than one passenger in the forward facing seat.
- Do not allow more than two passengers in the rear facing seat.
- Do not allow a passenger to ride anywhere on the vehicle except the passenger seat(s).
- Travel at speeds appropriate for your skills, your passenger's skills and the operating conditions. Avoid unexpected or aggressive maneuvers that could cause discomfort or injury to any passengers.
- Handling characteristics can change with added weight. Allow more time and distance for braking.

SLIPPERY SURFACES

⚠ WARNING

Skidding or sliding can cause a loss of control. Skidding or sliding can cause rollover if tires have lost traction, then regain traction suddenly. When operating on slippery surfaces, travel at reduced speed to help maintain control of the vehicle.

When operating in conditions such as ice, water, loose gravel, or freezing temperatures, follow these guidelines:

- Do not operate on excessively rough, slippery, or loose terrain.
- Slow down before entering potentially slippery areas.
- Maintain a high level of alertness
- Carefully evaluate the path of travel and avoid quick, sharp turns.
- Correct a skid by turning the steering wheel in the direction of the skid. *Never apply the brakes during a skid.*

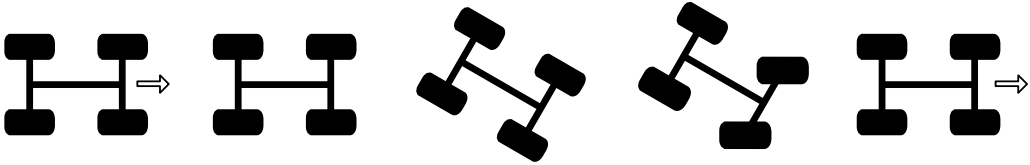

DRIVING UPHILL

When driving up a hill, follow these guidelines:

- Drive straight up the hill.
- Avoid excessively steep hills.
- Keep both feet on the floor or pedals.
- Check the terrain before driving up a hill. Do not try to climb hills that have excessively slippery or loose surfaces.
- Drive at a steady rate of acceleration and speed.
- Do not drive over the crest of a hill at high speed. An obstacle, sharp drop, or another person or vehicle could be on the other side of the hill.
- Do not attempt to drive up a hill that is beyond your skill level.

TRAVERSING HILLSIDES

⚠ WARNING

Traversing a hillside is not recommended. Improper procedure can cause loss of control or a rollover. Avoid crossing the side of a hill unless absolutely necessary. If traversing a hillside is unavoidable, check the terrain and determine if it can be accomplished safely. Do not proceed if the terrain is beyond the vehicle or driver's ability.

If traversing a hillside is unavoidable, follow these guidelines:

- Drive slowly.
- Use extreme caution.
- Avoid crossing the side of a hill that has a slippery surface.
- Avoid crossing the side of a steep hill.
- When traversing a hillside that has soft terrain, it may be necessary to steer slightly uphill to keep the vehicle traveling in a straight line.
- If you feel that you are losing control of the vehicle, steer downhill if possible to regain control.

DRIVING DOWNHILL



When carrying cargo or towing a vehicle or a trailer, the weight of the load will increase the braking distance required to slow or stop the vehicle. Not allowing for increased braking distance under load can cause an accident or injury.

When driving down a hill, follow these guidelines:

- Avoid excessively steep hills.
- Check the terrain carefully before descending any hill.
- Never drive down hills with excessively slippery or loose surfaces.
- Drive slowly.
- Drive straight down the hill. Avoid descending the hill at an angle that could cause the vehicle to lean sharply to one side.
- Apply light and constant pressure to the accelerator to maintain slow speed and control of the vehicle.

STALLING ON A HILL

A rollover can result from stalling or rolling backward while climbing a hill. Drive uphill at a constant speed.

If the vehicle completely stalls while climbing a hill:

1. Apply the brakes.
2. Verify that the area behind you is clear.
3. Turn the key switch to the reverse (R) position.
4. Use steady accelerator pressure to control the speed and allow the vehicle to slowly roll straight downhill.

DRIVING IN REVERSE

When driving in reverse, follow these guidelines:

- Check that the area behind the vehicle is clear of obstacles and people.
- Check left and right fields of vision before driving in reverse.
- Drive in reverse slowly.
- Press the brakes lightly for stopping.
- Accelerate slow and steady.
- Avoid turning at sharp angles.

PARKING THE VEHICLE



Park the vehicle on a flat surface if possible. If parking on an incline is unavoidable, be sure to chock the wheels to keep the vehicle from rolling.

1. Press the brake to stop the vehicle.
2. Turn the key switch to the OFF position.
3. Remove the key from the key switch to prevent unauthorized use.

OPERATION

HAULING CARGO ON THE LOAD DECK (VALOR 4 ONLY)

WARNING

Hauling cargo incorrectly can alter vehicle handling characteristics and cause loss of control, brake instability, and possibly lead to serious injury or death.

Never exceed the maximum weight capacity of the vehicle. The total load (operator, passenger, accessories, cargo, and load on hitch) must never exceed the maximum weight capacity of the vehicle. See the chart in *Maximum Weight Capacity* on page 26.

Position the load as far forward, and as low as possible on the load deck.

Secure all loads before operating. Unsecured loads can shift and create unstable operating conditions.

Operating the vehicle with passengers on the load deck can result in severe injury or death. Never allow a passenger to ride on the load deck. Passengers must always ride seated in the passenger seat.

Drive slowly and carefully.

Operate only with stable and safely arranged loads. When handling loads that are impossible to center on the load deck, make sure the load is secured as tightly as possible and operate the vehicle with extra caution.

Reduce speed and allow greater distances for braking when hauling cargo.

Heavy loads affect braking and handling characteristics. Use extra caution when applying brakes with a heavily loaded vehicle. Avoid terrain or situations that may require reverse downhill travel.

Use extra caution when operating with loads that extend over the load deck sides. Stability and maneuverability can be affected and increase risk of rollover.

WARNING

Never fill a gas container on the load deck. Static discharge can ignite gasoline vapor and cause an explosion.

Always put the gas container on the ground before you fill with gas. Never fill a gas container on the load deck. Static electricity is built up during the fueling process and can discharge and cause the gasoline vapor to ignite.

This vehicle is designed to carry specific capacities. Read and comply with the load distribution warnings on the warning label affixed to the load deck. The total load (operator, passenger, accessories, and cargo) must never exceed the maximum weight capacity of the vehicle.

Maximum Weight Capacity

	Valor	Valor 4
Maximum Vehicle Weight Capacity	500 lb (227 kg)	800 lb (363 kg)
Maximum Load Deck Weight Capacity	N/A	300 lb (136 kg)

- Do not exceed the maximum load deck weight capacity.
- Do not exceed the maximum vehicle weight capacity (includes weight of operator, passenger, cargo and accessories).

Flip Seat/Load Deck Operation

Some vehicles are equipped with a rear facing seat that pivots to form a load deck. The rear facing seat is designed for two passengers maximum.

WARNING

Do not allow more than two passengers on the rear facing seat. Never leave small children alone on the seat. Keep arms and legs inside the vehicle boundary at all times. Always fill the front seating capacity prior to seating any passengers on the rear seat.

To convert the seat to a load deck:

1. Remove any items from the seat.
2. Rotate the seat bottom toward the rear of the vehicle. The seat bottom board will rest in the two side frame pieces.

WARNING

To reduce the possibility of severe injury or death, DO NOT carry passengers on the load deck.

To convert the load deck to a passenger seat:

1. Remove any cargo from the load deck.
2. Rotate the rear portion of the load deck toward the front of the vehicle.

MAINTENANCE

MAINTENANCE SAFETY



To prevent serious injury or death, follow the procedures and comply with the safety information in this manual while performing vehicle service or maintenance.

Use the tools shown in the tool list and wear the specified safety equipment when performing vehicle service or maintenance.

Remove all jewelry before you service the vehicle.

Do not allow loose clothing or hair to contact the moving parts.

Do not touch hot objects.

Make sure that the key switch is in the OFF position and the key is removed before servicing the vehicle.

Disconnect the negative battery terminal before servicing the vehicle to prevent accidental operation.

The drive wheels must be lifted and supported on jack stands before performing any service to the powertrain when the motor is in operation.

Chock the wheels and support the vehicle with jack stands. NEVER get under a vehicle that is supported by a jack. Lift the vehicle according to the manufacturers instructions.

Wear a face shield when working around the batteries.

Be careful when working around batteries, using solvents, or using compressed air.

Use insulated tools within the battery area to prevent sparks or battery explosion.

The electrolyte in a battery is an acid solution which can cause burns to the skin and eyes. Completely clean all electrolyte spills that contact the skin or eyes with clear water. Contact a physician immediately.

Neutralize electrolyte spills with a solution of 2 teaspoons (10 ml) of sodium bicarbonate (baking soda) mixed in 1 quart (1 L) of water. Rinse with clean water.

To prevent the risk of battery explosion, keep all flammable materials, open flames or sparks away from the battery.

Maintain constant awareness that some components are heavy, spring loaded, corrosive, explosive, can cause high amperage, or get extremely hot. Battery acid and hydrogen gas can cause bodily injury

After making repairs or performing maintenance, test the vehicle in a safe area that is free from vehicle and pedestrian traffic.

SCHEDULED MAINTENANCE

Consistent inspection, adjustment, and lubrication of some components are necessary to maintain the *vehicle* so that it remains in safe and reliable condition. Refer to the *SCHEDULED MAINTENANCE CHART* on page 28 for detailed requirements.

Inspect, clean, lubricate, adjust, and replace parts as necessary. Use manufacturer or equivalent replacement parts.

Record the maintenance items performed along with details in the *SCHEDULED MAINTENANCE CHART* on page 28.

NOTICE: Service and adjustments are important for safe and reliable vehicle operation. If not familiar with safe service and adjustment procedures, have a certified dealer perform the operations.

MAINTENANCE

SCHEDULED MAINTENANCE CHART

Perform all services at the maintenance interval reached first.

Item	Interval (perform at interval that comes first)		Remarks	Page
	Hours	Calendar		
Overall vehicle condition	Pre-ride		Inspect.	
Batteries	Daily		Charge daily after use.	
Steering	Pre-ride		Check for smooth and free operation.	
Front suspension	Pre-ride		Inspect. Check for leaks and loose or missing hardware.	
Rear suspension	Pre-ride		Inspect. Check for leaks and loose or missing hardware.	
Tires	Pre-ride		Check condition and pressure.	32
Wheel lug nuts	Pre-ride		Check for loose or missing.	33
Accelerator	Pre-ride		Check for smooth operation.	
Brake system	Daily		Check for smooth operation and acceptable stopping distance.	
Frame hardware	Pre-ride		Check for loose or missing.	
Headlights and taillights	Pre-ride		Check operation. Replace bulbs as needed.	33
Reverse warning alarm	Pre-ride		Check operation.	
Switches	Pre-ride		Check operation.	
Fluid leakages	Pre-ride		Inspect entire vehicle for leaks	
Brake shoes	10	Monthly	Inspect. Replace as needed.	
Batteries	20	Monthly	Clean	
Batteries	20	Monthly	Check electrolyte level; fill with distilled water if required	
Charger receptacle	20	Monthly	Clean connections.	
Parking brake	20	Monthly	Conduct brake performance test; adjust as necessary. Check for correct hold on an incline.	
Accelerator	20	Monthly	Check for smooth operation.	
Wiring	20	Monthly	Inspect for loose connections, broken or missing insulation.	
Steering	20	Monthly	Check for excess play, loose or missing hardware.	
Tie rods	20	Monthly	Check for excess play, bent rods, loose or missing hardware.	
Front suspension	20	Monthly	Inspect strut for leaks. Check hubs and kingpins, for excessive play, worn bushings, loose or missing hardware.	
Rear axle	20	Monthly	Check for leakage; add oil as required.	
Brake system	20	Monthly	Check for smooth operation and acceptable stopping distance.	
Front wheel alignment	60	3 Months	Check for unusual tire wear.	
Rear Suspension	60	3 Months	Check for shock oil leakage, worn bushings, loose or missing hardware.	
General lubrication	50	3 Months	Lubricate all fittings, pivots, cables, etc. where required.	29
Rear axle	500	5 years	Replace fluid.	
Motor coupling	20,000 Amp Hours	5 years	Add anti-seize compound (approx. 1 tbsp.)	

RECOMMENDED LUBRICANTS AND FLUIDS

Check and lubricate all components at the intervals shown in the *SCHEDULED MAINTENANCE CHART* on page 28.

Item	Capacity	Lubricants/Fluids	Notes
Rear axle oil	25 oz. (0.7 L)	Mobil 424	Part Number 603967
Rear axle oil	2.0 oz (59 mL)	Friction Modifier E-Z-GO	Part Number 611242
Grease fittings		Universal joint grease or equivalent	Do not exceed 3 pumps of grease in each fitting.

REPLACEMENT OF MAINTENANCE ITEMS

These items or their equivalents can be purchased through an authorized dealer, directly from the manufacturer or any other qualified source.

Item	Part Number
10A 58V Mini Fuse	636455G22
10A 58V ATO Fuse	628840

VEHICLE CLEANING AND CARE

Keeping your vehicle clean is not only beneficial to its appearance, but can also help extend the life of various components.

Washing the Vehicle

NOTICE: *Do not use a pressure washer to wash the vehicle. High water pressure can damage components.*

Some products, including insect repellents and chemicals, will damage plastic surfaces. Do not allow these types of products to contact the vehicle.

- Do not use a pressure washer to clean the vehicle.
- Use an automotive type cleaner or mild soap to wash the vehicle. Harsh cleaners can scratch the finish.
- Use clean or new cloths and pads for washing. Reused cloths and pads can contain dirt particles that will scratch the finish.
- Use a sponge or soft brush and a soap/water solution to clean the vinyl seats. Rinse with clean water.
- To prevent the soap from drying on the vehicle, rinse with clean water frequently.
- Clean the windshield with water and a clean cloth. Remove small scratches with a plastic polish.
- Clean the bottom of the vehicle where mud or dirt can collect. Loosen any packed sediment to help with removal.
- Dry the vehicle with a chamois before the water dries to prevent water spots.
- Inspect all grease fittings for dirt intrusion or lack of grease after washing. Apply grease as required to maintain proper function.

Polishing the Vehicle

- Do not use medium to heavy duty compounds on the finish. Use wax that is for clear coat automotive finishes only. Do not apply wax or polish to matte finish surfaces.
- Use clean or new cloths and pads for polishing. Old or reused cloths and pads can contain dirt particles that will scratch the finish.

MAINTENANCE

BATTERY CONNECTIONS

Tools

- Insulated Wrench, 9/16"
- Socket, 9/16
- Ratchet

WARNING The batteries are heavy. Use correct lifting methods when you move them. Always lift the battery with a commercially available battery lifting device. Be careful not to tilt batteries when you remove or installing them; spilled electrolyte can cause burns and damage.

1. Turn key switch to the OFF position and remove the key.
2. Disconnect the main negative (-) battery cable (BL-).
3. Disconnect the main positive (+) battery cable (BL+).

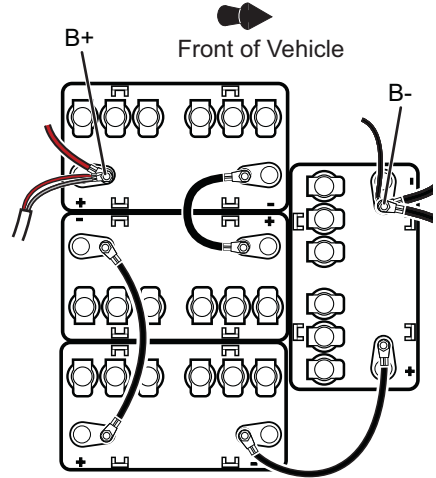

LIFTING THE VEHICLE

WARNING Read and comply with all of the following warnings and lifting procedures to prevent the possibility of the vehicle falling and causing serious injury or death.

For some maintenance procedures, it is necessary to lift the vehicle. Comply with the following warnings and follow the lifting procedure to ensure the safety of you, your vehicle, and surroundings.

WARNING The vehicle must be on a firm and level surface for lifting.

Remain constantly aware that the vehicle is not stable during the lifting process.

Place the jack and jack stands only in the areas indicated in the following illustration.

Do not get under a vehicle until it's stability on the jack stands is verified. Never get under a vehicle while it is on a jack only.

Put wheel chocks in front of and behind all wheels that are not being lifted.

Do not allow anyone to remain or get on the vehicle at any time during the lifting process or when the vehicle is lifted.

When performing any service to the drive-train, lift drive wheels off the ground.

Tools

- jack
- jack stands (4)
- wheel chocks

Remove any payload from the vehicle before lifting. Do not allow anyone in or on the vehicle while lifting.

Lifting the Entire Vehicle

1. Install wheel chocks in front and behind each front wheel.
2. Center the jack under the bag well.
3. Lift the vehicle enough to place two jack stands under the frame where the leaf spring mounting brackets are welded to the frame.
4. Lower the jack and test the stability of the vehicle on the two jack stands.
5. Place the jack under the center front just behind the bumper.
6. Lift the vehicle and place two jack stands under the frame where the instrument panel support is attached to the frame.
7. Lower the jack and test the stability of the vehicle on the jack stands.

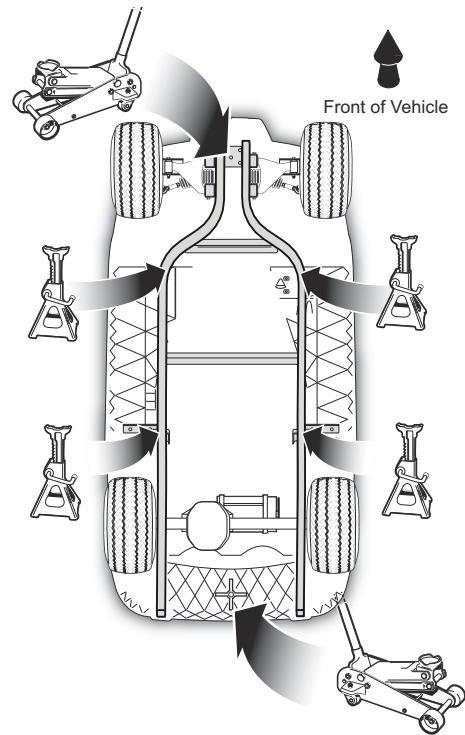
**Lifting the Rear of the Vehicle**

1. Install wheel chocks in front and behind each rear wheel.
2. Center the jack under the bag well.
3. Lift the vehicle enough to place two jack stands under the frame where the leaf spring mounting brackets are welded to the frame.
4. Lower the jack and test the stability of the vehicle on the jack stands.

Lifting the Front of the Vehicle

1. Install wheel chocks in front and behind each front wheel.
2. Place the jack under the center front just behind the bumper.
3. Lift the vehicle and place two jack stands under the frame where the instrument panel support is attached to the frame.
4. Lower the jack and test the stability of the vehicle on the jack stands.

Lowering the Vehicle

1. Lift the vehicle enough to remove the jack stands.
2. Carefully lower the vehicle to the ground with the jack.

MAINTENANCE

TIRES

Follow the tire maintenance procedures as instructed in this manual and on the labels on the vehicle. Always use approved size and type of replacement tires. See *VEHICLE SPECIFICATIONS* on page 43.

WARNING

Worn, improperly inflated, improper sized, or incorrectly installed tires will affect vehicle handling and could cause an accident resulting in severe injury or death.

Inflate all tires to the same pressure. Operating with unequal or incorrect pressure can adversely affect steering and handling and could cause an accident resulting in severe injury or death.

To decrease the risk of tire explosion, do not exceed the tire inflation rating on the tire sidewall. Make sure the tires are properly inflated at all times of operation.

To decrease the risk of tire explosion, inflate small amounts of air into the tire at intervals to allow the beads to seat properly. Because of the low volume of the small tires, over inflation can occur in seconds. Never exceed the tire inflation pressure rating on the tire sidewall when seating a bead. Protect your face and eyes when you remove a valve core.

When you remove the wheels, use only sockets made for impact wrenches to decrease the risk of injury by a broken socket.

Do not use tires with low rated pressure. Do not use tires that have a recommended tire inflation pressure less than the tire inflation pressure in *Tire Pressure* on page 32.

Do not over inflate the tires. Excess pressure can cause the tire to separate from the wheel or cause a tire explosion.

Tire Pressure

Maintaining correct tire inflation pressure is essential for safe vehicle operation. You can vary the inflation pressure, within the recommended range to suit the condition of the terrain.

TIRE PRESSURE RANGE	TERRAIN CONDITIONS	RECOMMENDATION
18 - 22 psi (124 - 152 kPa)	hard surfaces or pavement	Inflate to higher pressure within the range; never exceed maximum pressure indicated.
	soft terrain or turf	Inflate to lower pressure within the range to reduce potential damage to the terrain or turf.

Tire Repair

NOTICE: Tire repairs are not covered under the vehicle warranty.

Tools

- lug wrench, 3/4"
- impact wrench
- impact socket, 3/4"
- torque wrench, ft.lbs.

NOTICE: Tire plug tools and plugs are available at automotive outlets. The tire does not have to be removed from the wheel to install the tire plug.

Use a tire plug to repair small holes in the tread part of the tire. For large holes or holes/cuts in the tire sidewall, the tire must be replaced.

1. Remove the wheel from the vehicle. See *Wheel Removal* on page 33.
2. Locate the leak in the tire.
 - a. If the tire is very low or flat, fully inflate the tire.
 - b. Brush soapy water over the surface of the tire. Air bubbles will be visible where the air is leaking from the tire.
 - c. Mark the hole with chalk.
3. Install the plug according to the manufacturer's instructions.
4. Install the wheel on the vehicle. See *Wheel Installation* on page 33.
5. Fully inflate the tire. See *TIRE PRESSURE* on page 11.

Tire Replacement

Tire replacement requires a tire mounting machine and must be done by a qualified tire center or your local dealer.

WHEELS



WARNING Worn, improperly inflated, improper sized, or incorrectly installed tires will affect vehicle handling and could cause an accident resulting in severe injury or death.

NOTICE: To decrease the risk of component damage, do not tighten the lug nuts to more than the torque specified below.

Check lug nuts for tightness at the intervals indicated in the *SCHEDULED MAINTENANCE CHART* on page 28.

Wheel Removal

Tools

- lug wrench, 3/4"
- impact wrench
- impact socket, 3/4"
- torque wrench, ft.lbs.

1. Lift the vehicle. See *LIFTING THE VEHICLE* on page 30.
2. Remove the lug nuts.
3. Remove the tire from the vehicle.

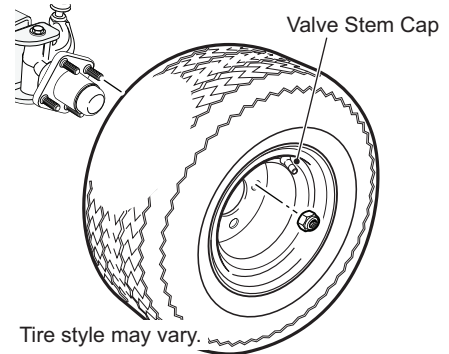

Wheel Installation

NOTICE: To decrease the risk of component damage, do not tighten the lug nuts to more than the specified torque.

Always install lug nuts using a cross sequence pattern to ensure even seating of the wheel against the hub.

1. Install the wheel on the hub with lug nuts. Make sure the valve stem is to the outside.
2. Finger tighten the lug nuts.
3. Using the tightening pattern shown at right, tighten the lug nuts to the torque values below. Tighten in increments of 20 ft. lbs. (27 Nm).

Lug Nut Tightening Pattern

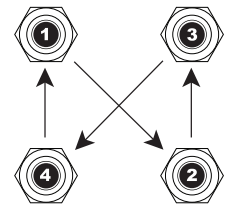

Lug Nut Torque	50 - 85 ft.lbs. (68 - 115 Nm)
----------------	-------------------------------

LIGHTS (IF EQUIPPED)

All of the lights on the vehicle are LEDs. They do not require replacement.

FUSE REPLACEMENT

The fuse block is under the forward facing seat.

NOTICE: Have the vehicle inspected by an authorized dealer if fuses continue to blow after they have been replaced.

1. Lift the seat bottom to access the fuses.
2. Remove the old fuse and replace it with a new fuse of the same type and size.
3. Fuses are available from a local dealer or the manufacturer.

MAINTENANCE

TRANSPORTING THE VEHICLE

WARNING

Do not ride or allow other people on a vehicle being transported on a trailer or being towed with another vehicle.

Hauling the Vehicle

WARNING

Loose cargo or vehicle components can fly off when the vehicle is being transported. Secure or remove all cargo. Inspect the vehicle for loose components prior to transport.

Do not allow anyone on a vehicle being transported on a trailer.

Remove the windshield before transporting a vehicle on a trailer.

- If the vehicle is being hauled on a trailer or truck at highway speeds, the canopy top must be removed.
- The rated capacity of the hauling trailer or truck must be more than the weight of the vehicle and load plus 1000 lb (454 kg). See VALOR on page 43 for the weight of the vehicle.

1. Drive the vehicle onto the trailer or truck.
2. Engage the parking brake.
3. Turn the key switch to the OFF position.
4. To prevent the loss of the key, remove it from the key switch.
5. Make sure the seat(s) are secured.
6. Secure the vehicle to the trailer or truck with tie downs, straps, or ropes.

Towing the Vehicle

WARNING

Only tow the vehicle for recovery purposes. Before towing, turn the key switch to N and move the Run/Tow switch to the TOW position. Ensure brakes and steering are operable. Always have a person driving the vehicle to steer and operate brakes when it is being towed. Do not tow the vehicle above 5 mph (8 kph). Failure to abide by these instructions could cause harm to vehicle and persons involved.

REAR AXLE

The only maintenance necessary for the first five years is the inspection of the rear axle for lubricant leakage. Unless leakage is visible, the lubricant needs to be replaced after five years. Refer to the service manual (available for purchase) for the fluid replacement procedure or have the service performed by a local dealer.

Checking the Lubricant Level

Clean the area around the check/fill plug and remove the plug. The correct lubricant level is just below the bottom of the threaded hole. If lubricant is low, add lubricant as required. Add lubricant (0 WT engine oil) slowly until lubricant starts to seep from the hole. Install the check/fill plug. In the event that the lubricant is to be replaced, the oil pan must be removed or the oil siphoned through the check/fill hole.

BATTERY CHARGING AND MAINTENANCE

Safety

Always obey the following warnings when working on or near batteries.



To prevent the risk of battery explosion, keep all flammable materials, open flames, or sparks away from the batteries.

Hydrogen gas is made as batteries are charged. Do not charge batteries without good ventilation. A 4% concentration of hydrogen gas is explosive.

Make sure that the key switch is in the OFF position, the key is removed from the switch, and all electrical accessories are off before servicing the vehicle.

Turn off all accessories before disconnecting from the battery terminal.



Use safe procedures to move the batteries. Always lift the battery with a commercially available battery lifting device.

Do not tilt the batteries during removal or installation. An electrolyte spill can cause burns and damage.

The electrolyte in a storage battery is an acid solution which can cause burns to the skin and eyes. Treat all electrolyte spills to the body and eyes with extended flushing with clear water. Contact a physician immediately.



Always wear a safety shield or approved safety goggles when adding water to the batteries.

Neutralize electrolyte spills with a solution of 2 teaspoons (10 ml) sodium bicarbonate (baking soda) mixed in 1 quart (1 liter) of water. Clean with water.

Filling the batteries with electrolyte above the maximum level can cause an electrolyte spill during the charge cycle. An electrolyte spill can cause damage to the vehicle and storage facility.

Be careful when using aerosol containers near the battery terminals. Use a container with insulation to prevent an explosion.

Use wrenches with insulation to decrease the risk of a short-circuit if a wrench falls across the battery terminals. A battery short-circuit can cause an explosion.

Battery Disposal

Lead-acid batteries are recyclable. Return used batteries to a distributor, the manufacturer, or a lead smelter for recycling. For neutralized spills, put residue in acid-resistant containers with absorbent material, sand or earth and discard according to state and federal regulations for acid and lead compounds. Contact state environmental officials for disposal information.

Battery

A battery is described as two dissimilar metals immersed in an acid. If the acid is absent or if the metals are not dissimilar, a battery has not been created. The batteries in this vehicle are lead acid.

A battery does not store electricity, but it can produce electricity as the result of a chemical reaction which releases stored chemical energy in the form of electrical energy. The chemical reaction occurs faster in warm conditions and slower in cold conditions. Temperature is important when conducting tests on a battery and test results must be corrected to adjust for temperature differences.

An older battery can perform adequately except that its capacity is decreased. Capacity describes the time that a battery can continue to supply its design amperes from a full charge.

A battery has a maximum life. Good maintenance maximizes the available life and decreases the conditions that can decrease the life of the battery.

MAINTENANCE

Battery Maintenance

Tools

- Insulated Wrench, 9/16"
- Socket, 9/16
- Battery Carrier
- Torque Wrench, in. lbs.
- Battery Maintenance Kit, 25587G01
- Battery Terminal Protectant

At Each Charging Cycle

- Before you charge the batteries, inspect the plug of the battery charger and vehicle receptacle housing for dirt or other particles.
- Charge the batteries after each use.

Monthly

- Inspect all wires for wear, loose connections, corrosion, or damage of insulation.
- Make sure that the electrolyte level is correct and add clean water as required.
- Clean the batteries and wire connections.

⚠ WARNING

Be careful when using aerosol containers near the battery terminals. Use a container with insulation to prevent an explosion.

- Apply battery protectant to the battery terminals.

Electrolyte Level and Water

The correct level of the electrolyte is 1/2" (13 mm) above the plates in each cell.

This level will leave approximately 1/4" - 3/8" (6 - 10 mm) of space between the electrolyte and the vent tube.

The electrolyte level is important because any part of the plates open to air will be damaged.

Do not overfill with water. Too much water pushes the electrolyte from the battery by release of gas and a decrease in volume of the electrolyte.

⚠ CAUTION

DO NOT overfill batteries. The charge cycle will expel electrolyte and cause component damage.

A battery being charged will produce hydrogen gas with most gassing occurring at the end of the charging cycle. Hydrogen gas is lighter than air. Water and sulphuric acid droplets will be carried out of the battery vents by the hydrogen gas, however, this loss is minimum. If the electrolyte level is high, the electrolyte will block the vent tube and the gas will push it out the vent tube and battery cap. The water will dry but the sulphuric acid will stay and damage the vehicle components and the storage facility floor. Sulphuric acid loss will weaken the amount of acid within the electrolyte and decrease the life of the battery.

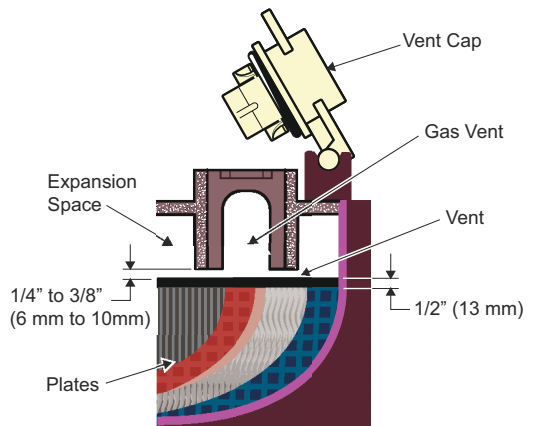

Electrolyte level should be at least 1/2" (13mm) above the plates and 1/4" to 3/8" (6 to 10 mm) below vent
Correct Electrolyte Level

Over the life of the battery, a large amount of water is used. The water used must be clean and without contamination. Water that is not clean decreases the life of the battery by reducing the chemical reaction. Use distilled water or filtered water only. Test water that is not distilled water and filter if needed. Refer to the water purity table for requirements.

Impurity	Parts Per Million
Color	Clear
Suspended	Trace
Total Solids	100
Calcium and Magnesium Oxides	40
Iron	5
Ammonia	8
Organic and Volatile Matter	50
Nitrites	5
Nitrates	10
Chloride	5

Water Purity Table

WARNING

The electrolyte in a battery is an acid solution which can cause severe burns to the skin and eyes. Clean all electrolyte spills to the body and eyes with clear water. Contact a physician immediately.



To clean an electrolyte spill, use a solution of 2 teaspoons (10 ml) sodium bicarbonate (baking soda) mixed with 1 quart (1 liter) of water.

Always wear a safety shield or approved safety goggles when adding water to the batteries.

Hand held watering devices available at an automotive parts store, or automatic watering devices like the one included in the Battery Maintenance Kit (P/N 25587G01) can be used with an approved water supply. These watering devices are accurate, easy to use, and allow for fast fill. They also keep the correct electrolyte level within the battery cells.

NOTICE: The watering device must only be used if the electrolyte level is less than 1/2" (13 mm) above top of plates.

Watering gun similar to the type included in the Battery Maintenance Kit

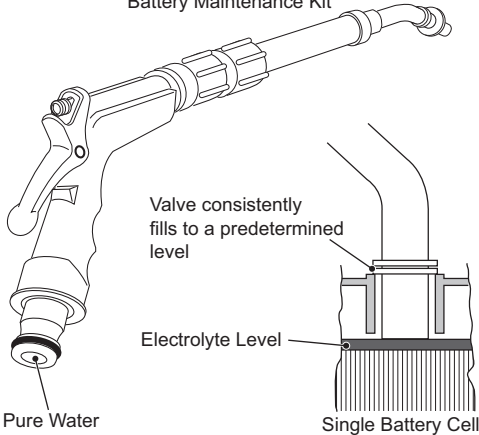

MAINTENANCE

Battery Cleaning



WARNING

To prevent battery damage, make sure all battery caps are installed correctly.

To decrease the risk of damage to vehicle or floor, neutralize acid before spraying the battery with water.

To decrease the risk of damage to the electrical components while cleaning, do not use a pressure washer.

Clean the batteries according to the scheduled maintenance chart on page 28.

When cleaning the battery cases and terminals, do not use a water hose without neutralizing any acid deposits first. The water hose moves the acid from the top of the batteries to another area of the vehicle or storage facility, where it can cause damage. After spraying the batteries, a conductive residue remains on the batteries and contributes to the discharge of the batteries.

The correct cleaning method is to spray the top and sides of the batteries with a solution of baking soda and water. Apply this solution with a plastic spray bottle. The solution is 2 teaspoons (10 ml) sodium bicarbonate (baking soda) mixed with 1 quart (1 liter) of water. Spray the solution on all metal components near the batteries also.

Allow the solution to set for a minimum of three minutes. Use a soft bristle brush or cloth to clean the top of each battery to remove residue that can cause the discharge of the battery. Clean the area with low pressure clear water.



WARNING

Be careful when using aerosol containers near the battery terminals. Use a container with insulation to prevent an explosion.

Clean once a month or more often in harsh conditions. After the batteries are clean and dry, apply a commercially available protectant to the terminals.

Prolonged Storage



CAUTION

Disconnect the battery charger, controller, and other electronic devices during extended storage. All connected electronic components cause the discharge of batteries.

NOTICE: Put the run/tow switch in the RUN position for extended storage of the vehicle to prevent draining of the batteries.

During storage, the batteries need attention to keep them maintained and prevent discharge. In high temperatures the chemical reaction is faster, while low temperatures cause the chemical reaction to slow. A vehicle that is stored at 90° F (32° C) will lose .002 of specific gravity each day. If a completely charged battery has a specific gravity of 1.275, and the battery is not used, it will become partially discharged.

When it reaches 1.240, which it will do in less than 20 days, it must be charged again. If a battery stays in a discharged state, sulfating occurs on and within the plates. This condition is not reversible and will cause permanent damage to the battery. To prevent damage, the battery must be charged again. Use a hydrometer to find the specific gravity and the state of charge of a battery.

In winter conditions, the battery must be completely charged to prevent the risk of freezing. A completely charged battery will not freeze in temperatures above -75° F (-60° C). Although the chemical reaction is decreased in cold temperatures, the battery must be stored completely charged, and disconnected from circuits that can discharge the battery. The controller must be disconnected from the batteries by disconnecting the battery cables. See *Battery Connections* on page 30.

For portable chargers, disconnect the charger plug from the vehicle receptacle.

For on-board chargers, disconnect the charging harness from the batteries.

The batteries must be cleaned and all deposits neutralized and removed from the battery case to prevent self-discharge. The batteries must be tested or charged again at 30 day minimum intervals.

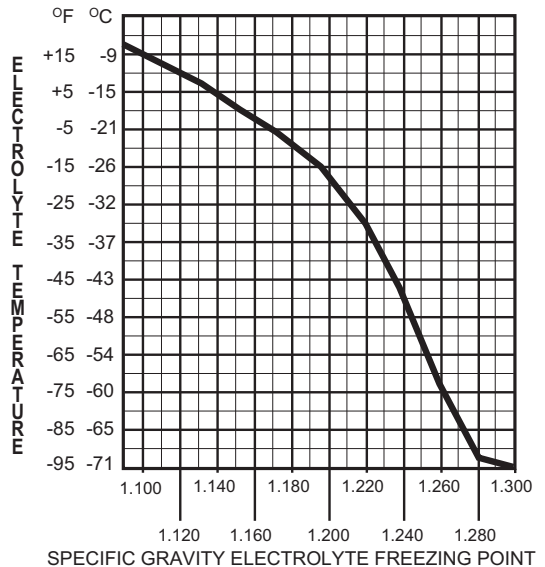

Battery Charging

The battery charger is designed to completely charge the battery set. If the batteries are severely deep cycled, some automatic battery chargers contain an electronic module that will not activate and the battery charger will not operate. An automatic charger determines the correct length of charge to the battery set and turns off when the batteries are charged. Always refer to the instructions of the charger used in the rear of this manual.



Do not overfill batteries. The charge cycle will expel electrolyte and cause component damage.

Before charging, the following must be observed:

- The electrolyte level in all cells must be at the recommended level and above the plates.
- The charging must occur in an area with good ventilation to remove hydrogen gas that is made during the charge cycle. A minimum of five air replacements for each hour is recommended.
- The charger connector components must be in good condition and free from dirt and particles.
- The charger connector must be completely installed in the vehicle receptacle.
- The charger connector and cord set must be protected from damage. The charger connector and cord set must be used in an area where it is not possible for personnel to run over or trip over the cord set.
- The charger automatically turns off during the connect and disconnect cycle so that no electrical arc is generated at the DC plug and receptacle contacts.

AC Voltage

The battery charger output is directly related to the input voltage. If the vehicle receives an incomplete charge in a normally adequate time period, low AC voltage can be the cause. Consult an electrician if necessary.

Fault Diagnosis

Fault diagnosis is done for two reasons:

- A battery that performs poorly and is outside of the manufacturers specification must be identified to replace it within the terms of the manufacturer's warranty. Different manufacturers have different requirements. Refer the battery manufacturer or the manufacturer's representative for specified requirements.
- Find the reason a vehicle does not perform adequately. Performance problems can cause a vehicle to run slowly or can not operate for the time needed.

A new battery must mature before it develops its maximum capacity. Maturing can take 100 or more charge and discharge cycles. After the maturing phase, the older a battery gets, the lower the capacity. The only method to find the capacity of a battery is a load test with a discharge machine. Refer to the discharge machine manufacturer instructions.

A hydrometer is used to identify a poorly performing battery in a set with a low specific gravity. When the particular cell or cells that are the problem are identified, the battery can be removed and replaced. The battery can not be restored. The individual battery should be replaced with a good battery of the same brand, type and approximate age.

MAINTENANCE

Hydrometer

A hydrometer is used to test the state of charge of a battery cell. This is performed by measuring the density of the electrolyte, which is accomplished by measuring the specific gravity of the electrolyte. The greater the concentration of sulfuric acid, the more dense the electrolyte becomes. The higher the density, the higher the state of charge.

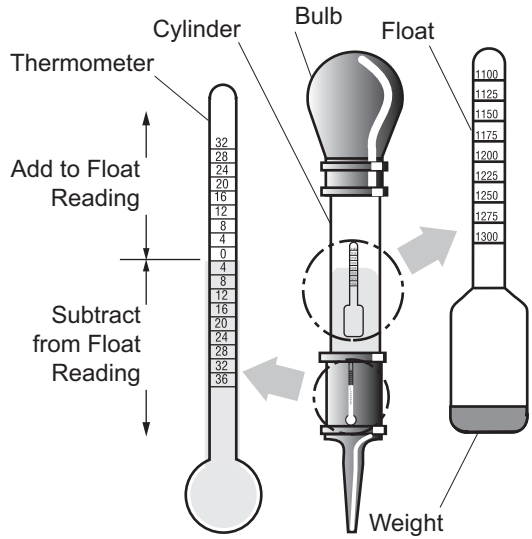

⚠ WARNING To prevent battery explosion, never insert a metal thermometer into a battery. Use a hydrometer with a built in thermometer that is designed for testing batteries.

Specific gravity is the measurement of a liquid that is compared to a baseline. The baseline is water which is assigned a base number of 1.000. The concentration of sulfuric acid to water in a new golf car battery is 1.280 which means that the electrolyte weighs 1.280 times the weight of the same volume of water. A fully charged battery will test at 1.275 - 1.280 while a discharged battery will read in the 1.140 range.

NOTICE: Do not perform a hydrometer test on a battery that has just been watered. The battery must go through at least one charge and discharge cycle in order to permit the water to adequately mix with the electrolyte.

The temperature of the electrolyte is important since the hydrometer reading must be corrected to 80° F (27° C). High quality hydrometers are equipped with an internal thermometer that will measure the temperature of the electrolyte and will include a conversion scale to correct the float reading. It is important to recognize that the electrolyte temperature is significantly different from the ambient temperature if the vehicle has been operated.

Using A Hydrometer



WARNING

To prevent battery explosion, never insert a metal thermometer into a battery. Use a hydrometer with a built in thermometer that is designed for testing batteries.



Always wear a safety shield or approved safety goggles when testing electrolyte using a hydrometer

1. Draw electrolyte into the hydrometer and release it several times to permit the thermometer to adjust to the electrolyte temperature and note the reading. Examine the color of the electrolyte. A brown or gray coloration indicates a problem with the battery and is a sign that the battery is nearing the end of its life.
2. Draw the minimum quantity of electrolyte into the hydrometer to permit the float to float freely without contacting the top or bottom of the cylinder.
3. Hold the hydrometer in a vertical position at eye level and note the reading where the electrolyte meets the scale on the float.
4. Add or subtract four points (.004) to the reading for every 10° F (6° C) the electrolyte temperature is above or below 80° F (27° C). Adjust the reading to conform with the electrolyte temperature, e.g., if the reading indicates a specific gravity of 1.250 and the electrolyte temperature is 90° F (32° C), add four points (.004) to the 1.250 which gives a corrected reading of 1.254. Similarly if the temperature was 70° F (21° C), subtract four points (.004) from the 1.250 to give a corrected reading of 1.246.
5. Test each cell and note the readings (corrected to 80° F or 27° C). A variation of fifty points between any two cell readings (example 1.250 - 1.200) indicates a problem with the low reading cell(s).

As a battery ages the specific gravity of the electrolyte will decrease at full charge. This is not a reason to replace the battery providing all cells are within fifty points of each other. Since the hydrometer test is in response to a vehicle exhibiting a performance problem, the vehicle should be recharged and the test repeated. If the results indicate a weak cell, the battery or batteries should be removed and replaced with a good battery of the same brand, type and approximate age.

ELECTROLYTE TEMPERATURE

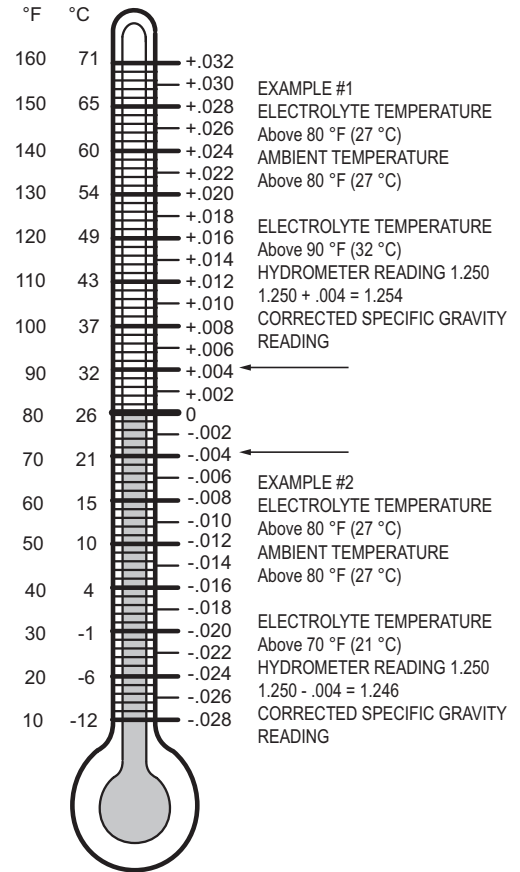

Hydrometer Temperature Correction

MAINTENANCE

VEHICLE SPECIFICATIONS

VALOR

Item	Specification
Overall Length	94.5 in (237 cm)
Overall Width	47 in. (119 cm)
Overall Height (no canopy)	46.7 in. (119 cm)
Overall Height (with canopy)	69.5 in. (177 cm)
Wheelbase	65.7 in. (167 cm)
Track Width (front)	35.5 in. (90 cm)
Track Width (rear)	38 in. (97 cm)
Ground Clearance at Differential	4.5 in. (11 cm)
Outside Clearance Circle	19.2 ft. (5.9 m)
Power Source	48 Volts DC
Motor Type	48 Volts AC
Horsepower (kW)	4.4 hp (3.3 kW) Continuous
Electrical System	48 Volt Primary, 12 Volt Auxiliary
Battery Quantity and Type	Four, 12 Volt Deep Cycle
Maximum Weight Capacity (includes weight of operator, passenger, cargo, accessories)	800 lbs. (363 kg)
Seating Capacity	2 person
Weight (No Batteries)	635 lbs. (290 kg) without batteries
Curb Weight	935 lbs. (425 kg)
Speed (Level Ground)	19 mph (28 kph)
Towing Capacity	N/A
Key or Pedal Start	Pedal
Speed Controller	Curtis 1206 AC Controller
Drivetrain	Motor Shaft Direct Drive
Trans-axle	Limited Slip Differential
Gear Selection	Dash Mounted Forward-Neutral-Reverse
Rear Axle Ratio	16.99:1
Steering	Double Ended Rack and Pinion
Front Suspension	Independent A-Arm Coil Over Shock
Rear Suspension	Mono-Leaf Springs with Hydraulic Shocks
Service Brake	Induction Motor
Parking Brake	Automatic Electro-Magnetic
Front Tires	KENDA K500, 20x8 - 10, 6-Ply
Rear Tires	KENDA K500, 20x8 - 10, 6-Ply
Frame	Welded Steel with DuraShield™ Powder Coat
Body and Finish	Injection Molded TPO
Turning Radius	9.6 ft (2.9 m)
Noise and vibration measurement methods were applied per the ISO 2631 and ISO 5349 standards under conditions of typical vehicle surfaces.	
Noise	Sound pressure: continued A-weighted equal to or less than 68 db (A)
Vibration, WBV	The highest RMS value of weighted acceleration is: 1.15 m/s ²
Vibration, HAV	The highest RMS value of weighted acceleration is: 2.5 m/s ²
	The uncertainty of measurement is 0.2 m/s ²

SPECIFICATIONS

VALOR 4

Item	Specification
Overall Length	105.5 in (268 cm)
Overall Width	47 in. (119 cm)
Overall Height (no canopy)	46.7 in. (119 cm)
Overall Height (with canopy)	75 in. (191 cm)
Wheelbase	65.7 in. (167 cm)
Track Width (front)	35.5 in. (90 cm)
Track Width (rear)	38 in. (97 cm)
Ground Clearance at Differential	4.5 in. (11 cm)
Outside Clearance Circle	19.2 ft. (5.9 m)
Power Source	48 Volts DC
Motor Type	48 Volts AC
Horsepower (kW)	4.4 hp (3.3 kW) Continuous
Electrical System	48 Volt Primary, 12 Volt Auxiliary
Battery Quantity and Type	Four, 12 Volt Deep Cycle
Maximum Weight Capacity (includes weight of operator, passenger, cargo, accessories)	800 lbs. (363 kg)
Seating Capacity	4 person
Weight (No Batteries)	781 lbs. (355 kg) without batteries
Curb Weight	1136 lbs. (516 kg)
Speed (Level Ground)	17 mph (31 kph)
Towing Capacity	N/A
Key or Pedal Start	Pedal
Speed Controller	Curtis 1206 AC Controller
Drivetrain	Motor Shaft Direct Drive
Trans-axle	Limited Slip Differential
Gear Selection	Dash Mounted Forward-Neutral-Reverse
Rear Axle Ratio	16.99:1
Steering	Double Ended Rack and Pinion
Front Suspension	Independent A-Arm Coil Over Shock
Rear Suspension	Mono-Leaf Springs with Hydraulic Shocks
Service Brake	Induction Motor
Parking Brake	Automatic Electro-Magnetic
Front Tires	KENDA K500, 20x8 - 10, 6-Ply
Rear Tires	KENDA K500, 20x8 - 10, 6-Ply
Frame	Welded Steel with DuraShield™ Powder Coat
Body and Finish	Injection Molded TPO
Turning Radius	9.6 ft (2.9 m)
Noise and vibration measurement methods were applied per the ISO 2631 and ISO 5349 standards under conditions of typical vehicle surfaces.	
Noise	Sound pressure: continued A-weighted equal to or less than 68 db (A)
Vibration, WBV	The highest RMS value of weighted acceleration is: 1.15 m/s ²
Vibration, HAV	The highest RMS value of weighted acceleration is: 2.5 m/s ²
	The uncertainty of measurement is 0.2 m/s ²



SAVE THESE IMPORTANT SAFETY INSTRUCTIONS



This manual contains important safety and operating instructions – read before using charger.

Warning: Use charger only with an algorithm selected that is appropriate to the specific battery type. Other usage may cause personal injury and damage. Lead acid batteries may generate explosive hydrogen gas during normal operation. Keep sparks, flames, and smoking materials away from batteries. Provide adequate ventilation during charging. Never charge a frozen battery. Study all battery manufacturers' specific precautions, ie. maximum charge rates and if cell caps should be removed while charging.

Danger: Risk of electric shock. Connect charger power cord to an outlet that has been properly installed and grounded in accordance with all local codes and ordinances. A grounded outlet is required to reduce risk of electric shock – do not use ground adapters or modify plug. Do not touch uninsulated portion of output connector or uninsulated battery terminals. Disconnect the AC supply before making or breaking the connections to the battery. Do not open or disassemble charger. Do not operate this charger if the AC supply cord is damaged or if the charger has received a sharp blow, been dropped, or otherwise damaged in any way – refer all repair work to the manufacturer, or qualified personnel. This appliance is not intended for use by persons (including children) with reduced physical, sensory or mental capabilities, or lack of experience and knowledge, unless they have been given supervision or instruction concerning use of the appliance by a person responsible for their safety. Children should be supervised to ensure that they do not play with the appliance.

INFORMATIONS IMPORTANTES DE SÉCURITÉ



Ce manuel contient des instructions importantes concernant la sécurité et le fonctionnement.

Attention: Utiliser le chargeur seulement avec un algorithme approprié au type spécifique de batterie. D'autres types de batteries pourraient éclater et causer des blessures ou dommages. Les batteries peuvent produire des gaz explosifs en service normal. Ne jamais fumer près de la batterie et éviter toute étincelle ou flamme nue à proximité des batteries. Fournissez une ventilation adéquate du chargement. Ne jamais charger une batterie gelée. Prendre connaissance des mesures de précaution spécifiées par le fabricant de la batterie, p. ex., vérifier s'il faut enlever les bouchons des cellules lors du chargement, et les taux de chargement.

Danger: Risque de chocs électriques. Ne pas toucher les parties non isolées du connecteur de sortie ou les bornes non isolées de la batterie. Toujours connecter le chargeur à une prise de courant mise à la terre. Déconnectez la source AC avant de faire ou défaire les connexions à la batterie en chargement. Ne pas utiliser le chargeur si le cordon d'alimentation AC est endommagé ou si le chargeur est abîmé suite à une chute ou autre incident. Ne pas ouvrir ni désassembler le chargeur – référer toute réparation aux personnes qualifiées. Cet appareil n'est pas destiné à un usage par des personnes (dont les enfants) avec des facultés motrices, sensorielles ou mentales réduites, ou ayant une expérience et des connaissances insuffisantes, à moins qu'elles sont sous la supervision ou reçoivent les instructions sur l'utilisation de l'appareil d'un répondant garant de leur sécurité. Les enfants devraient être surveillés afin qu'il ne jouent en aucun temps avec l'appareil.

Operating Instructions

CAUTION: Charger enclosure may be hot during charging. Use hand protection if handling the charger while charging.

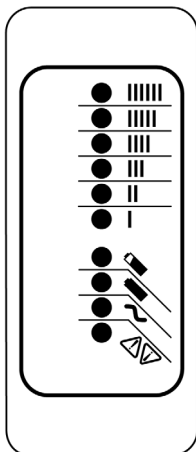

1. Extension cords must be 3-wire cord no longer than 30m(100') at 10AWG or 7.5m(25') at 16AWG per UL guidelines.
2. Only connect **ONE** QuiQ charger to a single 15A circuit or the circuit may become overloaded.
3. Charger 10-LED Display:

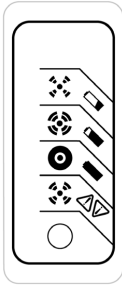

LED Colour	Indication (following "Power-On Self Test")
Ammeter (Amber)	Solid: Displays approximate scale of current output during bulk phase.
	Flashing: High internal charger temperature. Output reduced. Also displays algorithm #1-6 for 11 seconds if no battery is connected.
80% Charge (Amber)	Solid: Bulk charge phase complete, 80% charged. In Absorption phase.
	Flashing: With no battery connected, indicates algorithm # selected by number of flashes.
100% Charge (Green)	Solid: Charging complete. Charger in Maintenance Mode.
	Flashing: Absorption phase complete. In Finish phase
AC On (Amber)	Solid: AC Power good
	Flashing: Low AC Voltage, check voltage and extension cord length (see above for guidelines).
Fault (Red)	Flashing: Charger error. Reset charger power and refer to Troubleshooting Instructions below.

4. Optional Charger Single-LED Display (internal or external)









LED Colour	Indication (following "Power-On Self Test")	
Green	 Solid:	Charging complete. Charger in Maintenance Mode.
	 Flashing:	<i>Short:</i> <80% Charge. <i>Long:</i> >80% Charge. <i>When battery is not connected:</i> Algorithm Number display.
Amber	Flashing:	Reduced Power Mode: Low AC Voltage or High internal charger temperature.
Red	 Flashing:	Charger error. Reset charger power and refer to Troubleshooting Instructions below.

Maintenance Instructions

- Do not expose charger to oil, dirt, mud or direct heavy water spray when cleaning vehicle.
- If the detachable input power supply cord set is damaged, replace with a cord that is:
 - for North America - UL or CSA listed/approved detachable cord, 3 conductor, 16AWG minimum, and rated SJT; terminating in a grounding type IEC 60320 C14 plug rated 250V, 13A minimum; or
 - for all other countries – a safety approved detachable cord, 3 conductor, 1.5mm² minimum, rated appropriately for industrial use. The cord set must be terminated on one end with a grounding type input connector appropriate for use in the country of destination and, on the other end, an output grounding type IEC 60320 C14 plug.
- The enclosure of the charger has been tested successfully to EN60529, meeting IP66. The AC supply inlet is rated to IP20, which is suitable for indoor use only. Keep all AC connections clean and dry.

Troubleshooting Instructions

If a fault occurs, count the number of red flashes between pauses and refer to the table below:

Red Flashes	Cause	Solution
	Battery High Voltage	Check battery size and condition and reset charger (interrupt AC power for 15 seconds).
	Battery Low Voltage	Check battery size and condition and reset charger (interrupt AC power for 15 seconds).
	Charge Timeout caused by battery pack not reaching required voltage. Charger output was reduced due to high temperatures	Check connections. Operate charger at a lower ambient temperature.
	Check Battery: battery could not be trickle charged up to minimum voltage	Check for shorted or damaged cells.
	Over-Temperature: Charger shut down due to high internal temperature.	Ensure sufficient cooling air flow and reset charger (interrupt AC power for 15 seconds).
	Charger Internal Fault	Reset charger (interrupt AC power for 15 seconds). Return to qualified service depot if fault persists.

Note: This is a Class A product complying with United States Federal Communications Commission, Code of Federal Regulations; 47CFR part 15. In a domestic environment this product may cause radio interference, in which case the user may be required to take adequate measures.
2009 © Delta-Q Technologies Corp. All rights reserved. PN: 710-0098 Rev 1

INDEX

B

battery disposal 8

C

capacity

 cargo load 26

 fluids 29

cargo

 hauling 26

 maximum load 26

CEDURE 23

cleaning the vehicle 29

D

driving procedures

 accelerating 23

 downhill 25

 parking 25

 passenger 24

 stalling on hill 25

 traversing hillsides 24

 uphill 24

E

engine

 starting 23

F

fluids

 capacities 29

 recommended 29

I

ING 23

ing 23

K

key switch 18

L

labels, safety 9

lifting, vehicle 14, 30

lubricants, recommended 29

M

maintenance

 chart 28

 fluid capacities 29

 recommended fluids and lubricants 29

 scheduled 27

maintenance items 29

O

operator safety 12

P

parking brake, mechanical 19

PIN plate 8

pre-ride inspection 21

R

registration information, vehicle 7

S

safety

 cargo 26

 driving downhill 14

 driving in reverse 13

 driving uphill 14

 driving with passenger 13

 labels 9

 lifting, vehicle 14, 30

 operation 21

 operator 12

 pre-ride inspection 21

 slippery terrain 14

 stalling 14

 tire pressure 11, 32

 tires 14

 unauthorized use 12

 vehicle modification 14

 weight capacity 26

safety symbols 7

scheduled maintenance chart 28

serial number labels 8

SLIPPERY 24

switches

 key 18

T

tires 32

 pressure 11, 32

 repair 32

 replacement 32

V

vehicle identification numbers 8

W

warranty information, vehicle 7

washing the vehicle 29

weight capacity, maximum 26

wheels 33

 axle and wheel nut torques 33

 wheel installation 33

 wheel removal 33

Normal use, age, and wear on vehicle components can affect the safe operation and reliability of the vehicle. The recommended inspection and maintenance procedures are crucial for safety, performance, reliability and, maximum longevity of your vehicle.

A damaged vehicle, or a vehicle that is not functioning properly is dangerous and must not be operated until repairs are made.

NOTICE: Read the following operational warnings before driving the vehicle:

WARNING

Before exiting the vehicle, turn the key switch to the OFF position and remove the key from the vehicle to prevent unauthorized use.

Drive the vehicle at appropriate speeds for the terrain and conditions. Be aware of any environmental conditions that change the terrain and your ability to control the vehicle.

Do not drive on excessively steep hills. Evaluate the terrain before descending a hill. Drive slowly and deliberately. Use the brake to limit speed and maintain control. Sudden braking or turning can cause a loss of vehicle control. Drive straight down the hill; do not drive across the hill.

Operate in approved areas.

Keep both feet, legs, hands and arms inside vehicle at all times.

Avoid driving on terrain that is too rough for the vehicle's capabilities and your driving skills.

Before driving in the reverse direction, make sure the area behind the vehicle is clear. Accelerate slowly and avoid making sharp turns.

Make sure the direction selector is in the correct position before pressing the accelerator pedal.

Decrease speed before and during turns.

Bring the vehicle to a complete stop before moving the direction selector.

See *VEHICLE SPECIFICATIONS* on page 43 for the vehicle load and seat capacity.

NOTICE: Read the following maintenance information and warnings before servicing or repairing the vehicle:

Follow the procedures and comply with the safety information in this manual while performing vehicle service or maintenance.

Use the tools shown in the tool list and wear the specified safety equipment when performing vehicle service or maintenance.

WARNING

Remove all jewelry before servicing the vehicle.

Do not allow loose clothing or hair to contact the moving parts.

Do not touch hot objects.

The drive wheels must be lifted and supported on jack stands before performing any service to the powertrain while the engine is in operation.



When servicing the vehicle, always wear eye protection. Be careful when working around batteries, using solvents, or compressed air.

Use insulated wrenches to decrease the risk of a short-circuit if a wrench contacts the battery terminals. A short-circuit in a battery can cause an explosion.

To prevent the risk of battery explosion, keep all flammable materials, open flames, or sparks away from the batteries.

Hydrogen gas is produced as batteries are charged. Charge batteries only in well ventilated areas.

Maintain constant awareness that some components are heavy, spring loaded, corrosive, explosive, can cause high amperage, or get extremely hot. Battery acid and hydrogen gas can cause bodily injury. Keep your hands, face, feet and body away from any area that can expose them to injury if an unexpected situation occurs.



TEXTRON SPECIALIZED VEHICLES, INC.

1451 Marvin Griffin Road
Augusta, Georgia 30906 - 3852
USA

CONTACT INFORMATION

North America:

Technical Assistance & Warranty:

Phone: 1-800-774-3946, FAX: 1-800-448-8124

Service Parts Phone:

1-888-GET-E-Z-GO (1-888-438-3946), FAX: 1-800-752-6175

International:

Phone: 001-706-798-4311, FAX: 001-706-771-4609

California Proposition 65



WARNING

Operating, servicing and maintaining a passenger vehicle or off-road vehicle can expose you to chemicals including phthalates and lead, which are known to the State of California to cause cancer and birth defects or other reproductive harm. To minimize exposure, wear gloves and wash your hands frequently when servicing your vehicle.

For more information go to www.P65Warnings.ca.gov/passenger-vehicle

Parts Manuals and Service Manuals are available from a local Distributor, an authorized Branch, Genuine E-Z-GO Parts & Accessories Department or at www.shopezgo.com.

Copyrighted Material

This manual may not be reproduced in whole or in part without the express permission of the manufacturer.